

Архангельск (8182)63-90-72  
 Астана (7172)727-132  
 Астрахань (8512)99-46-04  
 Барнаул (3852)73-04-60  
 Белгород (4722)40-23-64  
 Брянск (4832)59-03-52  
 Владивосток (423)249-28-31  
 Волгоград (844)278-03-48  
 Вологда (8172)26-41-59  
 Воронеж (473)204-51-73  
 Екатеринбург (343)384-55-89  
 Иваново (4932)77-34-06

Ижевск (3412)26-03-58  
 Иркутск (395)279-98-46  
 Казань (843)206-01-48  
 Калининград (4012)72-03-81  
 Калуга (4842)92-23-67  
 Кемерово (3842)65-04-62  
 Киров (8332)68-02-04  
 Краснодар (861)203-40-90  
 Красноярск (391)204-63-61  
 Курск (4712)77-13-04  
 Липецк (4742)52-20-81  
 Киргизия (996)312-96-26-47

Магнитогорск (3519)55-03-13  
 Москва (495)268-04-70  
 Мурманск (8152)59-64-93  
 Набережные Челны (8552)20-53-41  
 Нижний Новгород (831)429-08-12  
 Новокузнецк (3843)20-46-81  
 Новосибирск (383)227-86-73  
 Омск (3812)21-46-40  
 Орел (4862)44-53-42  
 Оренбург (3532)37-68-04  
 Пенза (8412)22-31-16  
 Казахстан (772)734-952-31

Пермь (342)205-81-47  
 Ростов-на-Дону (863)308-18-15  
 Рязань (4912)46-61-64  
 Самара (846)206-03-16  
 Санкт-Петербург (812)309-46-40  
 Саратов (845)249-38-78  
 Севастополь (8692)22-31-93  
 Симферополь (3652)67-13-56  
 Смоленск (4812)29-41-54  
 Сочи (862)225-72-31  
 Ставрополь (8652)20-65-13  
 Таджикистан (992)427-82-92-69

Сургут (3462)77-98-35  
 Тверь (4822)63-31-35  
 Томск (3822)98-41-53  
 Тула (4872)74-02-29  
 Тюмень (3452)66-21-18  
 Ульяновск (8422)24-23-59  
 Уфа (347)229-48-12  
 Хабаровск (4212)92-98-04  
 Челябинск (351)202-03-61  
 Череповец (8202)49-02-64  
 Ярославль (4852)69-52-93

<https://chpbv.nt-rt.ru/> | | [cph@nt-rt.ru](mailto:cph@nt-rt.ru)



**MEIHUA INDUSTRIES**

► Description of product numbering method

- Body materials: C:Carbon steel Q:Nodular Cast iron Z:Gray cast iron P:304 Stainless steel R:316 Stainless steel T:Aluminum bronze
- Nominal pressure value
- Seal:F-PTFE X-RUBBER H-ALLOY STEEL
- Structure form:Butterfly valve(1-midline type,3-double eccentric type);ball valve (1-floating straight-way type);check valve(7-butterfly type,4-clack single flap type);gate valve(5-single slab non-rising stem wedge type, 1-single slab rising stem wedge type)
- Connecting form:4-flange;1-inner thread;7-welder
- Driving form:no-labeling is handle,handwheel,3-worm gear; 6-pneumatic 7-hydrodynamically operated;9-electrically operated
- Type:A-safety valve,D-butterfly valve;H-check valve;Q,Q-ball valve;Z:gate valve

► List of torques for the products

SIZE	D71X-10 10		D71X-10 15			D71X-10 20				D41X-10 10	D41X-10 15
	16 DN	10 DN	16 DN	10 DN	6 DN	10 DN	16 DN	25 DN	40 DN		
1"	9	8	7	8	7	8	7	8	7	8	7
1.5"	13	12	11	12	11	12	11	12	11	12	11
2"	18	15	14	16	14	16	14	16	14	16	14
2.5"	21	18	18	20	18	20	18	20	18	20	18
3"	26	23	24	26	24	26	24	26	24	26	24
4"	44	39	40	44	39	44	39	44	39	44	39
5"	54	50	48	54	47	51	47	51	47	51	47
6"	136	126	114	136	114	136	114	136	114	136	114
8"	260	230	217	260	217	260	217	260	217	260	217
10"	306	280	303	306	280	306	280	306	280	306	280
12"	517	430	514	430	350	430	350	430	350	430	350
14"	880	720	773	880	720	880	720	880	720	880	720
16"	1148	1017	1017	1148	1017	1148	1017	1148	1017	1148	1017
18"	1818	1730	1730	1818	1730	1818	1730	1818	1730	1818	1730
20"	2174	2000	2174	2174	2000	2174	2000	2174	2000	2174	2000
24"	2900	2700	2900	2900	2700	2900	2700	2900	2700	2900	2700
28"	3600	3600	3600	3600	3600	3600	3600	3600	3600	3600	3600

MEIHUA INDUSTRIES

# MEIHUA INDUSTRIES

## ► PRESSURE/TEMPERATURE

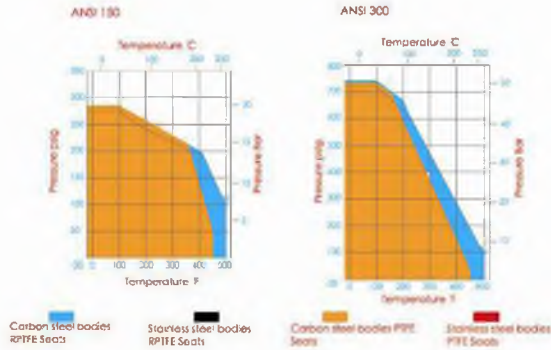

CLASS 150										
Degree Open %Full Cv										
Valve Size	10"	20"	30"	40"	50"	60"	70"	80"	90"	100"
2"	1.5	6	14	25	38	56	76	99	102	
2.5"	2.2	9	21	37	56	80	110	142	148	
3"	3.4	14	32	57	87	125	171	221	228	
4"	6.8	27	63	114	171	248	338	437	451	
5"	10.8	43	100	180	271	392	535	692	714	
6"	16.5	66	154	278	419	607	827	1070	1103	
8"	30.9	124	289	520	784	1135	1584	2002	2084	
10"	52.0	211	492	868	1336	1934	2638	3411	3517	
12"	72.0	290	677	1219	1838	2660	3628	4690	4837	
14"	90	392	914	1646	2481	3592	4808	6530	6857	
16"	132	531	1230	2229	3361	4865	6634	8845	9287	
18"	171	684	1598	3873	4332	6270	8550	11270	11400	
20"	207	828	1932	3478	5244	7590	10350	13800	14420	
24"	315	1260	2940	5292	7890	11550	15750	21000	22050	

CLASS 300										
Degree Open %Full Cv										
Valve Size	10"	20"	30"	40"	50"	60"	70"	80"	90"	100"
2"	1.5	6	14	25	38	56	76	99	102	
2.5"	2.2	9	21	37	56	80	110	142	148	
3"	3.4	14	32	57	87	125	171	221	228	
4"	6.8	27	63	114	171	248	338	437	451	
5"	10.8	43	100	180	271	392	535	692	714	
6"	16.5	66	154	278	419	607	827	1070	1103	
8"	27.3	109	255	459	692	1001	1365	1820	1911	
10"	52.0	211	492	886	1336	1934	2638	3411	3517	
12"	72.0	290	677	1219	1838	2660	3628	4690	4837	
14"	91	326	760	1365	2063	2965	4072	5430	5702	
16"	109	435	1015	1827	2755	3988	5438	7350	8243	
18"	139	555	1295	2331	3515	5088	6938	9250	9712	
20"	158	630	1470	2648	3990	5775	7875	10150	10838	
24"	242	996	2254	4057	6118	8855	12075	16100	18205	

## ► Double offset stem and disc design

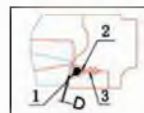
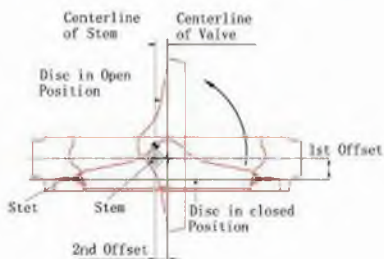

Seat non-compressed as disc approaches

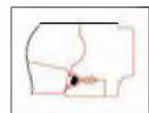

Disc in closed position, with no line pressure



Disc in closed position, line pressure applied from the bottom



Disc in closed position, line pressure applied from the top

► Double eccentric butterfly valve to U.S standard

D73- X150  
F300 (Z.Q.C.P.R)

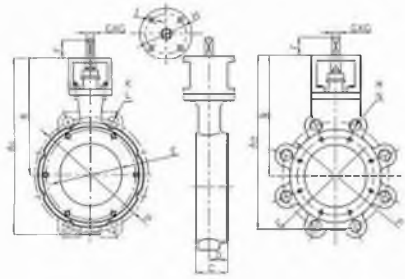

ANSI Class150															
SIZE	A <sub>1</sub>	A <sub>2</sub>	B	C	D	E	F	G×G	H	I	K	L	M	N	P
2"	9.42	9.42	6.42	1.75	1.06	2.45	1.25	0.433	2.76	0.354			3/8"-11	4	4.75
2.5"	9.13	9.13	6.42	1.88	1.09	2.91	1.25	0.433	2.76	0.354			3/8"-11	4	5.5
3"	10.4	10.43	7.4	1.92	1.2	3.37	1.25	0.433	2.76	0.354			3/8"-11	4	6
4"	11.73	11.73	8.23	2.13	1.28	4.25	1.25	0.433	2.76	0.354			3/8"-11	8	7.5
5"	13.32	13.95	9.07	2.25	1.34	5.3	1.25	0.551	2.76	0.354			3/4"-10	8	8.5
6"	14.5	14.5	9.6	2.31	1.38	6.4	1.25	0.551	2.76	0.354			3/4"-10	8	9.5
8"	16.3	16.76	10.75	2.5	1.49	8.35	1.25	0.669	4.02	0.433			3/4"-10	8	11.75
10"	18.28	19.26	11.36	2.81	1.7	10.16	1.62	0.866	4.02	0.433	0.94	2	7/8"-9	12	14.25
12"	23	23	13.48	3.23	1.86	11.93	2	1.063	5.51	0.71	0.94	2	7/8"-9	12	17
14"	25.16	25.16	14.09	3.82	2.19	13.94	2	1.063	5.51	0.71	1.06	4	1"-8	12	18.75
16"	27.66	27.66	15.6	4	2.31	15.59	2	1.417	6.5	0.866	1.06	4	1"-8	16	21.25
18"	32	32	18.82	4.5	2.45	17.48	2.5	1.417	6.5	0.866	1.25	4	1 1/8"-7	16	22.75
20"	34.23	34.23	20.29	5	2.94	19.45	2.5	1.811	6.5	0.866	1 1/8"-7	4	1 1/8"-7	20	25
24"	38.58	38.58	22.13	6.06	3.12	23.3	3.01	1.811	6.5	0.866	1 1/8"-7	4	1 1/8"-7	20	29.5

ANSI Class300															
SIZE	A <sub>1</sub>	A <sub>2</sub>	B	C	D	E	F	G×G	H	I	K	L	M	N	P
2"	9.41	9.37	6.42	1.75	1.06	2.45	1.25	0.433	2.76	0.354			3/8"-11	8	5
2.5"	9.13	9.13	6.42	1.88	1.09	2.91	1.25	0.433	2.76	0.354			3/8"-10	8	5.88
3"	10.39	10.47	7.4	1.92	1.2	3.37	1.25	0.433	2.76	0.354			3/4"-10	8	6.625
4"	11.73	11.93	8.23	2.13	1.26	4.25	1.25	0.433	2.76	0.354			3/4"-10	8	7.875
5"	13.31	13.43	9.07	2.25	1.34	5.3	1.25	0.551	2.76	0.354			3/4"-10	8	9.25
6"	14.53	14.53	9.81	2.29	1.38	6.4	1.25	0.669	4.02	0.433			3/4"-10	12	10.625
8"	16.66	17.92	10.76	2.88	1.54	8.35	1.25	0.866	4.02	0.433			7/8"-9	12	13
10"	19.23	19.74	11.88	3.25	1.7	10.16	1.62	1.063	4.02	0.433	1"-8	2	1"-8	16	15.25
12"	23.64	23.64	13.83	3.82	1.86	11.93	2	1.063	5.51	0.71	1 1/8"-8	2	1 1/8"-8	16	17.75
14"	26.85	26.85	15.77	4.82	2.48	13.94	2	1.417	5.51	0.71	1 1/8"-8	4	1 1/8"-8	20	20.25
16"	29.21	29.21	16.91	5.25	2.59	15.59	2	1.417	6.5	0.866	1 1/8"-8	4	1 1/8"-8	20	22.5
18"	33.41	33.41	19.96	5.88	3.03	17.48	2.5	1.811	6.5	0.866	1 1/8"-8	4	1 1/8"-8	24	24.75
20"	36.11	36.11	21.55	6.31	3.24	19.45	2.5	1.811	6.5	0.866	1 1/8"-8	4	1 1/8"-8	24	27
24"	41.69	41.69	24.26	7.19	3.62	23.3	3.01	1.811	6.5	0.866	1 1/2"-8	4	1 1/2"-8	24	32

► Double eccentric butterfly valve to German standard

D73- X10  
F40 (Z.Q.C.P.R)

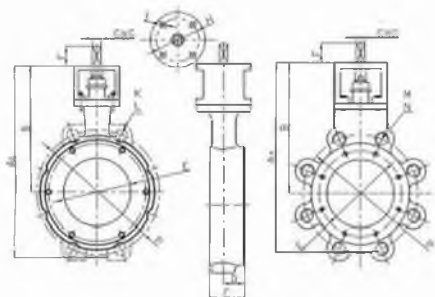

PN10

SIZE	A	A <sub>1</sub>	B	C	D	E	F	ΦG	H	I	K	L	M	N	P
2"	239	239	163	43	25.2	62	40	14	70	9			M16	4	125
2.5"	232	232	163	46	25.8	74	40	14	70	9			M16	4	145
3"	264	264	188	46	28.7	86	40	18	70	9			M16	8	160
4"	298	298	209	52	30.2	108	50	18	70	9			M16	8	180
5"	338	338	230	56	32.2	135	50	20	70	9			M16	8	210
6"	369	369	244	56	33.25	162	50	20	70	9			M20	8	240
8"	423	423	273	60	36.05	210	60	25	70	9			M20	8	295
10"	483.5	483.5	299	68	41.38	250	60	30	102	11	22	2	M20	12	350
12"	564	564	342	78	45.5	303	60	35	140	18	22	2	M20	12	400
14"	639	639	358	92	56	354	60	35	140	18	22	4	M20	16	480
16"	702.5	702.5	396	102	58.7	386	60	50	185	22	26	4	M24	16	515
18"	813	813	478	114	62.23	444	110	60	185	22	26	4	M24	20	565
20"	869.4	869.4	515	127	74.7	484	110	60	185	22	M24	4	M24	20	620
24"	980	980	562	154	79	582	130	60	185	22	M27	4	M27	20	725

PN16

SIZE	A	A <sub>1</sub>	B	C	D	E	F	ΦG	H	I	K	L	M	N	P
2"	239	239	163	43	25.2	62	40	14	70	9			M16	4	125
2.5"	232	232	163	46	25.8	74	40	14	70	9			M16	4	145
3"	264	264	188	46	28.7	86	40	18	70	9			M16	8	160
4"	298	298	209	52	30.2	108	50	18	70	9			M16	8	180
5"	338	338	230	56	32.2	135	50	20	70	9			M16	8	210
6"	369	369	244	56	33.25	162	50	20	70	9			M20	8	240
8"	423	423	273	60	36.05	210	60	25	70	9			M20	12	298
10"	483.5	483.5	299	68	41.38	250	60	30	102	11	26	2	M24	12	355
12"	564	564	342	78	45.5	303	60	35	140	18	26	2	M24	12	410
14"	639	639	358	92	56	354	60	35	140	18	26	4	M24	16	470
16"	702.5	702.5	398	102	58.7	386	60	50	185	22	30	4	M27	16	525
18"	813	813	478	114	62.23	444	110	60	165	22	30	4	M27	20	585
20"	869.4	869.4	515	127	74.7	484	110	60	165	22	M30	4	M30	20	650
24"	980	980	562	154	79	582	130	60	185	22	M33	4	M33	20	770

PN25

SIZE	A	A <sub>1</sub>	B	C	D	E	F	ΦG	H	I	K	L	M	N	P
2"	239	239	163	43	25.2	62	40	14	70	9			M16	4	125
2.5"	232	232	163	46	25.8	74	40	14	70	9			M16	4	145
3"	264	264	188	46	28.7	86	40	18	70	9			M16	8	160
4"	298	298	209	52	30.2	108	50	18	70	9			M20	8	190
5"	338	338	230	56	32.2	155	50	20	70	9			M24	8	220
6"	369	369	244	56	33.25	162	50	20	70	9			M24	8	250
8"	423	423	273	60	36.05	210	60	25	70	9			M24	12	310
10"	483.5	483.5	299	68	41.38	250	60	30	102	11	30	2	M27	12	370
12"	564	564	342	78	45.5	303	60	35	140	18	30	2	M27	16	430
14"	660	660	378	92	56	354	60	35	140	18	33	4	M30	16	490
16"	722.5	722.5	416	102	58.7	396	60	50	185	22	36	4	M33	16	550
18"															
20"															
24"															

PN40

SIZE	A	A <sub>1</sub>	B	C	D	E	F	ΦG	H	I	K	L	M	N	P
2"	239	239	163	43	25.2	62	40	14	70	9			M16	4	125
2.5"	232	232	163	46	25.8	74	40	14	70	9			M16	4	145
3"	264	264	188	46	28.7	86	40	18	70	9			M16	8	160
4"	298	298	209	52	30.2	108	50	18	70	9			M20	8	190
5"	338	338	230	56	32.2	155	50	20	70	9			M24	8	220
6"	369	369	244	56	33.25	162	50	20	70	9			M24	8	250
8"	423	423	273	60	36.05	210	60	25	70	9			M27	12	320
10"	483.5	483.5	299	68	41.38	250	60	30	102	11	33	2	M30	12	385
12"	564	564	342	78	45.5	303	60	35	140	18	33	2	M30	16	450
14"															
16"															
18"															
20"															
24"															



► Double eccentric double flanged butterfly valve to German standard

D43- X10  
F40 (Z.Q.C.P.R)

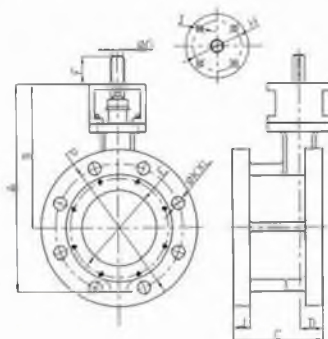

PN10

SIZE	A	B	C	D	E	F	ΦG	H	I	K	L	J	P
2"	238	163	106	25.2	60	40	14	70	9	18	4	20	125
2.5"	232	163	112	25.8	70	40	14	70	9	18	4	20	145
3"	264	188	114	28.7	84	40	18	70	9	18	8	22	180
4"	298	209	127	30.2	106	50	18	70	9	18	8	24	180
5"	338	230	140	32.2	130	50	20	70	9	18	8	28	210
6"	389	244	140	33.25	154	50	20	70	9	22	8	28	240
8"	423	273	152	36.05	196	60	25	70	9	22	8	30	296
10"	483.5	289	165	41.38	245	60	30	102	11	22	12	32	350
12"	581	342	178	45.5	293	60	35	140	18	22	12	32	400
14"	638	358	190	58	340	60	35	140	18	22	16	36	480
16"	698	406	218	58.7	385	80	50	165	22	28	18	37	515
18"	768	478	222	62.23	431	110	50	185	22	28	20	40	565
20"	873	615	229	74.7	482	110	60	185	22	28	20	42	620
24"	1022	812	247	79	580	130	60	165	22	30	20	44	725

PN16

SIZE	A	B	C	D	E	F	ΦG	H	I	K	L	J	P
2"	238	163	106	25.2	60	40	14	70	9	18	4	20	125
2.5"	232	163	112	25.8	70	40	14	70	9	18	4	20	145
3"	264	188	114	28.7	84	40	18	70	9	18	8	22	180
4"	298	209	127	30.2	106	50	18	70	9	18	8	24	180
5"	338	230	140	32.2	130	50	20	70	9	18	8	28	210
6"	389	244	140	33.25	154	50	20	70	9	22	8	28	240
8"	423	273	152	36.05	196	60	25	70	9	22	8	30	296
10"	483.5	289	165	41.38	245	60	30	102	11	28	12	32	355
12"	581	342	178	45.5	293	60	35	140	18	28	12	32	410
14"	638	358	190	58	340	60	35	140	18	28	16	36	470
16"	698	408	218	58.7	385	80	50	185	22	30	18	37	525
18"	768	478	222	62.23	431	110	50	185	22	30	20	40	585
20"	873	615	229	74.7	482	110	60	185	22	33	20	42	660
24"	1022	812	247	79	580	130	60	165	22	36	20	44	770

PN25

SIZE	A	B	C	D	E	F	ΦG	H	I	K	L	J	P
2"	238	163	106	25.2	60	40	14	70	9	18	4	20	125
2.5"	232	163	112	25.8	70	40	14	70	9	18	4	20	145
3"	264	188	114	28.7	84	40	18	70	9	18	8	22	180
4"	298	209	127	30.2	106	50	18	70	9	22	8	24	180
5"	338	230	140	32.2	130	50	20	70	9	28	8	28	220
6"	389	244	140	33.25	154	50	20	70	9	28	8	28	250
8"	423	273	152	36.05	196	60	25	70	9	28	12	30	310
10"	483.5	289	165	41.38	245	60	30	102	11	30	12	32	370
12"	581	342	178	45.5	293	60	35	140	18	30	16	32	430
14"	638	358	190	58	340	60	35	140	18	33	16	36	490
16"	698	408	218	58.7	385	80	50	185	22	36	18	37	550
18"													
20"													
24"													

PN40

SIZE	A	B	C	D	E	F	ΦG	H	I	K	L	J	P
2"	238	163	106	25.2	60	40	14	70	9	18	4	20	125
2.5"	232	163	112	25.8	70	40	14	70	9	18	4	20	145
3"	264	188	114	28.7	84	40	18	70	9	18	8	22	180
4"	298	209	127	30.2	106	50	18	70	9	22	8	24	180
5"	338	230	140	32.2	130	50	20	70	9	28	8	28	220
6"	389	244	140	33.25	154	50	20	70	9	28	8	28	250
8"	423	273	152	36.05	196	60	25	70	9	30	12	30	320
10"	483.5	309	165	41.38	245	60	30	102	11	33	12	32	385
12"	581	342	178	45.5	293	60	35	140	18	33	16	32	450
14"													
16"													
18"													
20"													
24"													

## ► Midline valve to U.S. standard

D71X-<sup>X125</sup>  
F150 (Z.Q.C.P.R)

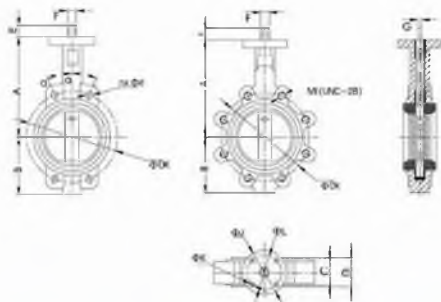

Valve Size		A	B	C	D	E	ΦF	G	H	a	ΦJ	ΦDk x n x Φd	ΦL	ΦDk x n x Ml	ΦK	Weight (kg)	
DN	IN															Lug	Wafer
50	2"	162	82	42	48.1	32	12.8	10		45°	90	120.65 x 4 x 17.5	70	120.65 x 4 x 5/8"-11	9.5	3.18	2.72
65	2-1/2"	178.6	90.5	44.2	49.1	32	12.8	10		45°	90	130.7 x 4 x 17.5	70	130.7 x 4 x 5/8"-11	9.5	3.63	3.18
80	3"	181	96.5	45	48.4	32	12.8	10		45°	90	152.4 x 4 x 17.5	70	152.4 x 4 x 5/8"-11	9.5	6.35	4.54
100	4"	200	114	52	55.3	32	15.77	12		22.5°	90	190.5 x 4 x 17.5	70	190.5 x 8 x 5/8"-10	9.5	11.79	5.5
125	5"	212.7	128	54.4	58.8	32	18.92	14		22.5°	90	215.9 x 4 x 20.64	70	215.9 x 8 x 3/4"-10	9.5	12.7	8.18
150	6"	225.03	141	55.7	59.1	32	18.92	14		22.5°	90	241.3 x 4 x 20.64	70	241.3 x 8 x 3/4"-10	9.5	14.06	9.0°
200	8"	260.35	179	60.5	64.1	45	22.1	17		22.5°	150	298.45 x 4 x 20.64	102/125	298.45 x 8 x 3/4"-10	11.1/14.3	22.23	14.41
250	10"	292	204	68.5	71.8	47.6	28.45	22		15°	150	361.95 x 4 x 23.81	102/125	361.95 x 12 x 7/8"-9	11.1/14.3	32.66	19.55
300	12"	338.8	241.8	78.9	81	47.8	31.8	24		15°	150	431.8 x 4 x 23.81	125	431.8 x 12 x 7/8"-9	14.3	47.83	31.75
350	14"	388.3	287.5	78.8	81	47.8	31.8	24		15°	150	478.25 x 4 x 26.99	125	478.25 x 16 x 1"-8	14.3	70.31	43.09
400	16"	400	318	65.7	90	50.8	33.2		7.94	11.25°	150	539.75 x 4 x 27	125	539.75 x 16 x 1"-8	14.3	88.45	63.07
450	18"	422	336	104	109	50.8	37.95		9.52	11.25°	210	577.85 x 4 x 31.75	165	577.85 x 16 x 1-1/8"-7	20.65	104.33	74.84
500	20"	478	372	128	132	63.50	41.12		9.52	9°	210	635 x 4 x 31.75	165	635 x 20 x 1-1/8"-7	20.65	179.62	124.74
600	24"	582	460	151	158	89.85	50.82		12.7	9°	210	749.3 x 4 x 34.93	185	749.3 x 20 x 1-1/4"-7	20.65	278.7	199.58

## ► Midline valve to German standard

D71X-<sup>X10</sup>  
F16 (Z.Q.C.P.R)

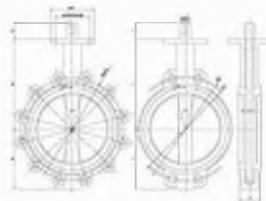

Valve Size		L	A	B	C	ΦD1	ΦDmax Φd2	ΦD1	Weight(kg)	
DN	IN								Wafer	Lug
80	3-1/2"	36	81	130	32	50	90 x 4 x 7	65	2.4	2.6
90	2"	43	83	130	32	52	70 x 4 x 9	90	2.8	4.2
95	2-1/2"	46	95	140	32	52	70 x 4 x 9	90	3.2	5
98	3"	46	102	145	32	52	70 x 4 x 9	90	4.3	6.5
100	4"	52	128	160	32	54	70 x 4 x 9	90	5.4	8
125	5"	56	137	170	32	58	70 x 4 x 9	90	7.5	10.2
150	6"	56	149	190	32	58	70 x 4 x 9	90	9.3	12
200	8"	60	181	230	48	22	102 x 4 x 11	125	10.8	18
250	10"	68	210	260	48	26	102 x 4 x 11	125	24.5	28.2
300	12"	78	248	290	48	30	128 x 4 x 14	150	31	44
350	14"	92	279	320	48	30	135 x 4 x 14	150	48.5	66
400	16"	102	305	350	50	32	165 x 4 x 22	210	55	80
450	18"	114	360	380	50	35	165 x 4 x 22	210	75	105
500	20"	127	371	420	64	40	180 x 4 x 22	210	135	180
600	24"	154	451	470	70	50	254 x 8 x 18	300	200	277
700	28"	165	520	524	100	63.5	254 x 8 x 18	300	216	296
800	32"	190	581	612	120	83.2	254 x 8 x 18	300	260	340
900	36"	203	623	768	130	74.2	254 x 8 x 18	300	388	480
1000	42"	214	668	823	130	83.2	254 x 8 x 18	300	470	620
1200	48"	254	755	980	156	92	298 x 8 x 22	380	690	900

► Midline valve to Italian standard  
D71X- $\frac{10}{16}$  (Z.Q.C.P.R)

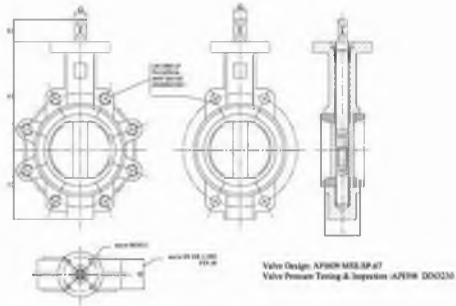

Valve DN	Size IN	L	A	B	C	G x G	ΦD x n x Φd2	ΦD1	Weight (kg)	
									Welder	Lug
40	1-1/2"	36	61	130	32	11x11	50 x 4 x 7	66	2.4	2.8
50	2"	43	83	130	32	11x11	70 x 4 x 9	90	2.8	4.2
65	2-1/2"	46	96	140	32	11x11	70 x 4 x 9	90	3.2	5
80	3"	48	102	145	32	11x11	70 x 4 x 9	90	4.3	6.5
100	4"	52	124	160	32	11x11	70 x 4 x 9	90	5.4	8
125	5"	56	137	170	32	14x14	70 x 4 x 9	90	7.5	10.2
150	6"	56	149	180	32	14x14	70 x 4 x 9	90	9.3	12
200	8"	60	161	220	45	17x17	102 x 4 x 11	126	12.8	16
250	10"	68	210	260	45	22x22	102 x 4 x 11	125	24.5	29.2
300	12"	78	248	290	45	22x22	125 x 4 x 14	150	31	44

► Double-axis valve without pin(back-seated type)  
D71X- $\frac{10}{16}$  (Z.Q.C.P.R)

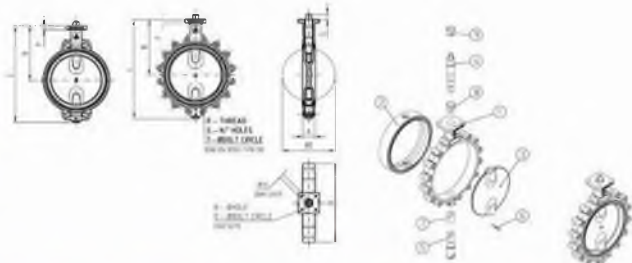

DN	A	B	C	E	F	G	□H	DN	ØD	ISO5211	ANSI 150		DIN PN10			
											R	S	R	S		
50	44	142.9	216.2	58.3	11	15	14	7/8	50/70	F05/F07	5/8" -11 UNC	4	120.7	M16-2P	4	125
65	47	155.6	235.2	72.5	11.6	15	14	7/8	50/70	F05/F07	5/8" -11 UNC	4	139.7	M16-2P	8	145
80	47	161.9	247.8	84.7	11.4	15	14	7/8	50/70	F05/F07	5/8" -11 UNC	4	152.4	M16-2P	8	160
100	53.5	181	281.1	108.6	12	15	14	7/8	50/70	F05/F07	5/8" -11 UNC	8	190.5	M16-2P	8	180
125	57	196.9	309.5	128.8	11.7	20	17	9	7/8	F07	3/4" -10 UNC	8	215.9	M16-2P	8	210
150	57	209.6	334.3	153.9	11.5	20	17	9	7/8	F07	3/4" -10 UNC	8	241.3	M20-2.5P	8	240
200	63	238.7	397.1	199.4	13	20	17	9/11	70/102	F07/F10	3/4" -10 UNC	8	298.5	M20-2.5P	8	295
250	71	285.9	475.9	248.2	15	25	17	11	102	F10	7/8" -8 UNC	12	362	M20-2.5P	12	350
300	81	308.6	551.7	300.0	14.5	25	22	11	102	F10	7/8" -8 UNC	12	431.8	M20-2.5P	12	400
350	76.5	350	628.6	335.8	22.5	30.7	27	13	125	F12	1" -8 UNC	12	476.3	M20-2.5P	16	460
400	99.0	374.7	678.2	381.7	22.3	30.7	27	13	125	F12	1" -8 UNC	16	539.8	M24-3P	16	515
450	112.0	401.6	744.3	436	21.7	38.7	36	17	140	F14	1 1/8" -8 UNC	16	577.0	M24-3P	20	565
600	124.5	427	795.6	486.8	22.3	38.7	36	17	140	F14	1 1/8" -8 UNC	20	635	M24-3P	20	620
600	152.0	490.5	918.9	593.4	25.6	56	48	22	185	F16	1 1/2" -8 UNC	20	749.3	M27-3P	20	725

► Double -axis valve without pin(soft seat)

D71X- $\frac{10}{16}$  (Z.Q.C.P.R)



Valve Size	A	B	C	L	ΦF	ΦD1mm Φd1(ΦD2)mm Φd2	Sp/Φd
DN50	96	140	13	40.2	90	Φ88×4×Φ16/Φ50×4×Φ7	11×11
DN65	67	152.4	13	44	90	Φ76×4×Φ10/Φ50×4×Φ7	11×11
DN80	71.5	158	13	44	90	Φ70×4×Φ10/Φ50×4×Φ7	11×11
DN100	86	178	13	50.5	90	Φ70×4×Φ10/Φ50×4×Φ7	14×14
DN125	106	190	13	52.4	90	Φ70×4×Φ10	16×14
DN150	118	203	13	52.4	90	Φ70×4×Φ10	14×14
DN200	153	241	18	67.5	125	Φ102×4×Φ12/Φ70×4×Φ19	17×17
DN250	188	272	18	63.5	125	Φ102×4×Φ12/Φ70×4×Φ19	22×22
DN300	214	311	18	76.2	150	Φ125×4×Φ14/Φ102×4×Φ12	22×22
DN350	230	346	35	76	150	Φ125×4×Φ14	Φ28
DN400	276	375	35	102	150	Φ125×4×Φ14	Φ36

► Double -axis valve without pin(soft seat)

D71x- $\frac{10}{16}$  (Z.Q.C.P.R)



ITEM	H <sub>1</sub>	H <sub>2</sub>	h	Φd <sub>1</sub>	b×b	ΦD <sub>2</sub>	ΦD <sub>1</sub>	Φd <sub>2</sub>	C	C <sub>1</sub>	ΦD	n-M
SIZE												
2"	80	140	31	14	11×11	90	70	10	43	47	125	4-M16
2.5"	70	152	31	14	11×11	90	70	10	46	50	145	4-M16
3"	80	159	31	14	11×11	90	70	10	46	50	160	8-M16
4"	90	178	31	16	14×14	90	70	10	52	56.5	180	8-M16
5"	112	181	31	18	14×14	90	70	10	56	60.5	210	8-M16
6"	126	203	31	18	14×14	90	70	10	56	60.5	240	8-M20
8"PN10	155	243	38	22	17×17	152	125	14	60	64.5	295	8-M20
8"PN16	155	243	38	22	17×17	152	125	14	60	64.5	295	12-M20
10"PN10	187	273	38	26	22×22	152	125	14	66	72.5	350	12-M20
10"PN16	187	273	38	26	22×22	152	125	14	66	72.5	355	12-M24
12"PN10	220	311	38	26	22×22	152	125	14	78	85	400	12-M20
12"PN16	220	311	38	26	22×22	152	125	14	78	85	410	12-M24



## ► Double-axis valve without pin (soft seat) D71x-<sup>10</sup>/<sub>16</sub> (Z.Q.C.P.R)

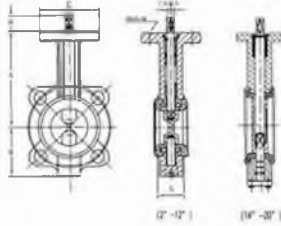

Valve Size		A	B	C	n X n	H	L	ΦD X 4-Φd	Weight (kg)
DN	IN								
60	2"	161	79	90	11×11	30	43	70×4-9	3.5
65	2-1/2"	160	93	90	11×11	30	46	70×4-9	4
80	3"	165	103	90	11×11	30	46	70×4-9	4.4
100	4"	165	120	90	14×14	30	52	70×4-9	6.5
125	5"	210	133	90	14×14	30	56	70×4-9	7.8
150	6"	210	158	125	17×17	30	56	70×4-9/102×4-12	10.8
200	8"	250	180	125	17×17	30	61.5	70×4-9/102×4-12	14.8
250	10"	266	216	125	22×22	30	66	102×4-12	22.2
300	12"	321	251	150	22×22	30	78	102×4-12/125×4-14	33.5
350	14"	346	262	150	22×22	45	78	125×4-13	47.4
400	16"	375	300.8	176	27×27	45	102	140×4-17	51.4
450	18"	400	333	175	27×27	45	114	140×4-17	102.4
500	20"	432	366	176	36×36	45	127	140×4-17	111.5

## ► Single-axis valve without pin (soft seat) D71x-<sup>10</sup>/<sub>16</sub> (Z.Q.C.P.R)

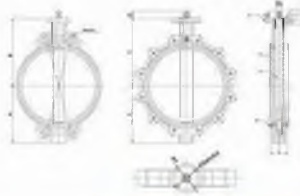

Valve Size		L	A	B	C	ΦD X n X Φd	Sq/Φd1	ΦF	Torque(N.m)
DN	IN								
50	2"	40.2	83	130	13	70×4×9	10×10	90	20
65	2.5"	44	95	140	13	70×4×9	10×10	90	40
80	3"	44	102	145	13	70×4×9	10×10	90	40
100	4"	51	114	160	13	70×4×9	10×10	90	60
125	5"	63.4	137	170	17	70×4×9	14×14	90	80
150	6"	63.1	149	180	17	70×4×9	14×14	90	100
200	8"	60	181	220	20	102×4×12	17×17	125	700
250	10"	66	210	280	22	102×4×12	19×19	125	300
300	12"	78.2	246	290	26	125×4×14	22×22	150	400
350	14"	78	279	320	26	125×4×14	22×22	150	800
400	16"	102	292.8	350	27	165×4×22	24×24	210	1000
450	18"	114	356	380	30	185×4×22	27×27	210	1100
500	20"	12*	357	420	33	165×4×22	30×30	210	1200

## ► Double-flange butterfly valve

D41X- $\frac{10}{16}$ (Z.Q)

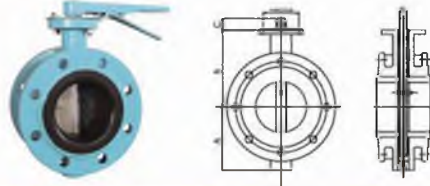

Valve Size	L	A	B	C	Φd	Φdk×n×ΦD2	Weight(kg)
DN 50	108	83	130	32	12	70×4×9	7.8
65	112	95	140	32	12	70×4×9	9
80	114	102	145	32	12	70×4×9	22
100	128	124	160	32	14	70×4×9	25
125	140	137	170	32	18	70×4×9	27
150	140	149	190	32	18	70×4×9	30
200	152	181	220	45	22	102×4×11	48
250	185	210	260	45	25	102×4×11	66
300	178	248	290	45	30	125×4×14	77
350	190	279	320	45	30	125×4×14	99
400	218	305	350	50	32	165×4×22	200
450	222	365	380	50	35	165×4×22	225
500	229	371	420	66	40	165×4×22	273
600	267	457	470	60	50	254×8×18	320
700	292	480	560	72	55	254×8×22	450
750	307	520	585	72	55	254×8×18	510
800	318	525	610	72	55	254×8×18	620
900	330	635	680	77	75	254×8×18	710
1000	410	685	740	85	85	254×8×18	910
1200	470	870	856	150	92	298×8×22	1450

## ► U-type flange butterfly valve

D41X- $\frac{10}{16}$ (Z.Q)

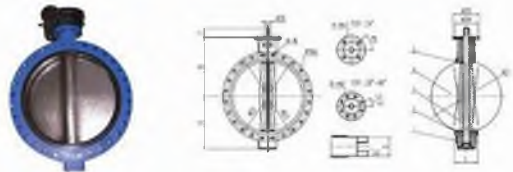

DN	ΦD1	ΦD2	ΦD3	ΦD4	ΦD5	ΦD6	M	N°Φd	A	B	C	D	L	b	Φd1
150	165.8	240		70	90	19.82	—	8*22	149	226	32	56	59	12.5	9
200	202.1	296		102	123	22.1	—	8*22	180	260	45	80	64	15.5	12
250	250.2	350	395	102	125	28.45	M20	8*22	205	292	45	68	71.8	17.5	12
300	301.1	400	445	125	150	31.6	M20	8*22	247	337	45	78	81	21	14
350	333.3	480	505	125	150	31.6	M20	12*22	267	368	45	92	95	28	14
400	289.6	515	565	165	210	33.34	M24	12*28	297	400	51	102	104	30	22
450	440.3	565	615	165	210	36.1	M24	16*28	318	422	51	114	116	30	22
500	491.6	620	670	165	210	41.28	M24	16*28	448	480	64	127	129	32	22
600	592.5	725	780	165	210	50.82	M27	16*30	456	502	70	154	156	38	22
700	695	840	895	254	300	63.35	M27	20*30	520.2	624	66	165	171	40	18
800	794.7	950	1015	254	300	63.35	M30	20*33	591.2	672	66	190	198	44	18
900	864.7	1050	1115	254	300	75	M30	24*33	656	720	118	203	211	48	18
1000	965	1180	1230	254	300	85	M33	24*38	721	800	142	216	224	50	18
1050	1030.7	1257.3	1348	298	350	95	M37	32*41.3	777.2	858	150	251	261	66	22
1200	1160.6	1380	1455	298	350	105	M36	28*40	864	940.7	150	254	264	58	22

### ► Split type butterfly valves

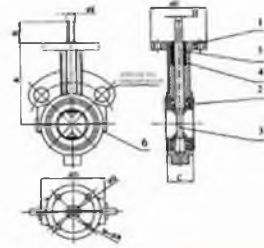

Valve Size	VALVE BODY(mm)							TOP FLANGE TABLE(mm)			
DN	IN	A	B	C	D	E	H	ISO5211	ΦQ	F	N-ΦR
25	1"	90	25.4	30	81	10	8	F05	50	65	4-Φ7
40	1-1/2"	104	25.4	32	81	10	8	F05	50	65	4-Φ7
50	2"	140	32	41.1	94	14	10	F07	70	90	4-Φ10
65	2-1/2"	152	32	44.5	108	14	10	F07	70	90	4-Φ10
80	3"	159	32	44.5	124	14	10	F07	70	90	4-Φ10
100	4"	178	32	51	154	16	11	F07	70	90	4-Φ10
125	5"	190	32	54	181	19	13	F07	70	90	4-Φ10
150	6"	203	32	54	206	19	13	F07	70	90	4-Φ10
200	8"	241	32	63.5	267	22	18	F12	125	150	4-Φ10
250	10"	273	50	63.5	324	30	22	F12	125	150	4-Φ14
300	12"	311	50	76.2	378	30	22	F12	125	150	4-Φ14

### ► Split type butterfly valve with PTFE seat

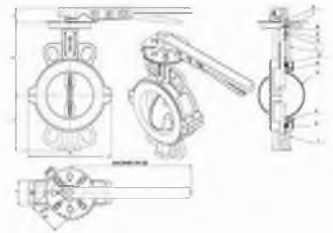

DN(mm)	SIZE						FLANGE	N-Φ1	E	Φ	Q×Q
	A	B	C	L	H	K					
50	74	136	117	43	32	65	DINPN10 DINPN16 ANSI150	4-6.7	50	12.7	11
65	82	138	126	46	32	65		4-6.7	50	12.7	11
80	90	138	142	46	32	65		4-6.7	50	12.7	11
100	115.8	158	178	52	32	90		4-10.3	70	15.8	14
125	132.5	174	202	56	32	90		4-10.3	70	19	14
150	145.5	190	234	56	32	90		4-10.3	70	19	14
200	179.5	229	286	60	45	125		4-14.5	102	22.2	17
250	216.5	269	350	68	45	125		4-14.6	102	28.6	22
300	253.5	300	402	78	45	125		4-14.7	102	31.8	22

► Double-opening check valve

H77X- $\frac{10}{16}$  (Z-Q)

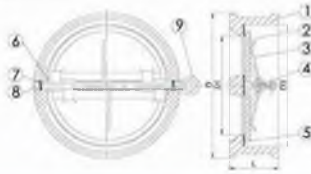

Valve Size		D			D1	D2	L	Weight(kg)
DN	IN	PN10	PN16	ANSI 150				
50	2"		109	105	40	70.5	43	2
65	2.5"		129	124	60	83.5	46	2.8
80	3"		144	137	70	90.5	64	4
100	4"		164	175	88	115.5	64	5
125	5"		194	197	115	142.5	70	6.5
150	6"		220	222	134	169.5	76	9.5
200	8"		275	278	182	220.5	89	15.5
250	10"		330	340	220	275.5	114	29
300	12"		380	410	260	325.5	114	48
350	14"	440	445	451	298	380	127	58
400	16"	491	498	514	350	410	140	76
450	18"	539	550	549	385	450	152	45
500	20"	596	620	606	438	505	152	107
600	24"	698	737	718	538	624	178	165

► Rubber-coated check valve

H47X- $\frac{10}{16}$  (Z-Q)

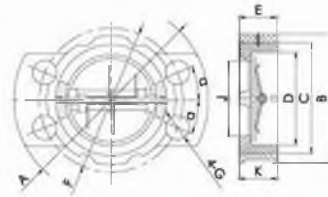

Valve Size		ΦA	ΦB	ΦC	ΦD	E	ΦF	ΦG	a	ΦJ	K	Weight(kg)
DN	IN											
50	2"	159	101	84.8	86.7	50	125	18	45°	47.6	54	2.3
65	2-1/2"	178	120	99	79.4	50	145	18	45°	56.7	54	2.8
80	3"	200	133	118.4	92.1	50	180	18	22.5°	69.9	54	4
100	4"	220	171	143.4	117.5	60	180	18	22.5°	87.3	63.5	6.8
125	5"	250	198	172	144.4	63.8	210	18	22.5°	112.7	66.7	9.2
150	6"	286	222	200.6	171.5	76.5	240	22	22.5°	141.3	76.4	12
200	8"	340	280	254.5	222.3	97.2	295	22	22.5°	192.1	99.7	20
250	10"	406	336	309	276.2	98.4	350	22	15°	230.2	101.8	27
300	12"	482	406	368.2	327	127	400	22	15°	274.8	130.8	46
350	14"	533	450	394.2	355.6	177	480	22	11.25°	304.8	181	62
400	16"	598	488	488	406.4	167	515	26	11.25°	305.6	182	78
450	18"	635	545	506.8	460	191	585	28	9°	406.4	184.2	100
500	20"	715	595	553	508	221	620	28	9°	480.3	216	110





## MEIHUA INDUSTRIES

▶ Check valve to U.S standard  
H77X-125  
150 (Z-Q)

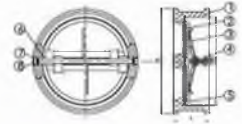

DN		D	D2	L
MM	IN			
50	2"	104.78	70	53.98
65	2.5"	123.83	83.3	53.98
80	3"	136.53	90.5	57.15
100	4"	181.93	115.5	63.50
125	5"	195.24	144.46	69.85
150	6"	222.25	169.5	74.2
200	8"	279.40	220.5	95.25
250	10"	339.73	275.5	107.95
300	12"	406.40	325.5	142.88
350	14"	422.28	356	184.15
400	16"	502.70	404	190.50
450	18"	549.28	487	203.2
500	20"	606.43	514.35	212.73
600	24"	717.55	616	222.75

▶ Check valve to U.S standard

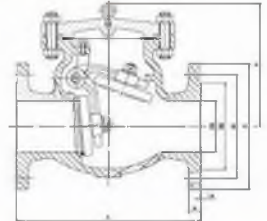

Valve Size		Class 150Lb							
IN	L	D	D1	D2	s	n-d	H	W(kg)	
2"	203	152	120.7	92	15.8	4-19	132	15	
2.5"	218	178	139.7	105	17.5	4-19	147	20	
3"	241	190	152.4	127	19	4-19	176	27	
4"	292	229	190.5	157	23.9	8-19	198	45	
5"	330	254	215.9	186	23.9	8-22	255	58	
6"	358	278	241.3	218	25.4	8-22	320	66	
8"	495	343	296.5	270	28.5	8-22	380	131	
10"	622	408	362	324	36.2	12-28	440	219	
12"	699	483	431.8	381	31.8	12-28	480	321	
14"	787	533	478.3	413	35	12-28	530	380	
18"	864	597	539.8	470	36.6	18-28	580	560	
18"	978	636	577.9	533	36.6	18-32	620	630	
20"	978	690	635	584	42.9	20-32	657	770	
24"	1295	813	749.3	692	47.8	20-35	780	980	
30"	1524	978	914.4	857	74.6	28-35	980	1990	

Valve Size		Class 300Lb							
IN	L	D	D1	D2	s	n-d	H	W(kg)	
2"	203	165	127	92	22.2	8-19	132	15	
2.5"	218	190	149.2	105	25.4	8-22	147	20	
3"	241	210	168.3	127	28.6	8-22	178	27	
4"	292	254	200	157	31.8	8-22	198	45	
5"	330	278	235	186	34.9	8-22	256	58	
6"	358	318	268.9	218	36.5	12-22	320	69	
8"	495	381	330.2	270	41.3	12-25	380	131	
10"	622	445	387.3	324	47.6	18-29	440	219	
12"	699	521	460.8	381	50.8	18-32	480	321	
14"	787	584	514.3	413	54	20-32	530	380	
18"	864	648	571.5	470	57.2	20-35	580	560	
18"	978	711	628.7	533	60.3	24-35	620	630	
20"	978	775	685.4	584	63.5	24-35	657	770	
24"	1295	914	812.8	692	69.9	24-41	780	980	
30"	1524	1092	997	857	92	28-48	980	1990	

## ► Swing check valve threaded(ANSI 200PSI)

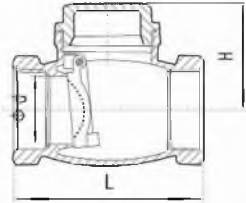

PART LIST			DIMENSION TABLE						
ITEM	DESIGNATION	MATERIAL	SIZE	1/2"	3/4"	1"	1 1/4"	1 1/2"	2"
1	BONNET	CF8M	ITEM						
2	GASKET	PTFE	d	15	20	25	32	40	50
3	BODY	CF8M	L	65	80	90	105	120	140
4	HANGER PIN	304	H	43	53	60	60	75	79
5	PLUG GASKET	PTFE							
6	PLUG	304							
7	DISC	CF8M							

## ► Gate valve to U.S standard 150/300

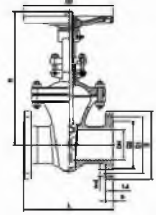
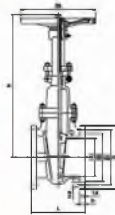

Class 150Lb										Class 300Lb											
Valve Size	IN	L	D	D1	D2	b	n-d	H	D0	W	Valve Size	IN	L	D	D1	D2	b	n-d	H	D0	W
2"	177.8	152	120.7	92	15.8	4-19	342	250	23		2"	215.9	165	127	92	22.2	8-19	356	250	30	
2.5"	190.5	178	139.7	105	17.5	4-19	372	250	30		2.5"	241.3	190	149.2	105	25.4	8-22	395	250	39	
3"	203.2	190	152.4	127	19	4-19	390	250	36		3"	282.5	210	168.3	127	28.6	8-22	440	250	55	
4"	228.6	229	190.5	157	23.9	8-19	458	300	53		4"	304.8	254	200	157	31.8	8-22	500	300	83	
5"	254	254	215.9	186	23.9	8-22	545	300	71		5"	381	279	235	186	34.9	8-22	587	300	92	
6"	268.7	279	241.3	216	25.4	8-22	602	360	85		6"	403.4	318	269.9	216	36.5	12-22	630	360	137	
8"	292.1	343	298.5	270	28.5	8-22	753	400	136		8"	419.1	381	330.2	270	41.3	12-25	763	400	240	
10"	330.2	406	362	324	30.2	12-25	934	400	220		10"	457.2	445	387.3	324	47.6	16-29	982	400	378	
12"	355.6	483	431.8	381	31.8	12-25	1102	500	323		12"	501.7	521	450.8	381	50.8	16-32	1160	500	536	
14"	381	533	476.3	413	35	12-29	1207	600	378		14"	762	584	514.3	413	54	20-32	1310	600	880	
16"	406.4	597	539.8	470	36.6	16-29	1350	650	553		16"	838.2	648	571.5	470	57.2	20-35	1545	650	1080	
18"	431.8	635	577.9	533	39.6	16-32	1472	650	660		18"	914.4	711	628.7	533	60.3	24-35	1623	650	1300	
20"	457.2	699	635	584	42.9	20-32	1630	800	810		20"	990.6	775	685.4	584	63.5	24-35	1770	800	1190	
24"	508	813	749.3	692	47.8	20-35	1920	800	1250		24"	1143	914	812.8	692	69.9	24-41	2102	800	2800	
30"	610	978	914.4	857	74.6	28-35	3140		2480		30"	1397	1092	997	857	82	28-48	3540		3786	
32"	711	1060	978	914.4	80.8	28-41	3280		2950		32"	1524	1149	1054	914.4	98.6	28-51	3760		4400	

## ► Non-rising gate valve



DN	L	D	D0	D1	D2	b	f	n-d	H
40	140	150	130	110	88	19	3	4-19	---
50	150	165	130	125	102	19	3	4-19	202
65	170	185	130	145	122	19	3	4-19	222
80	180	200	150	160	138	19	3	8-19	250
100	190	220	165	180	158	19	3	8-19	303
125	200	250	185	210	188	19	3	8-19	351
150	210	285	195	240	212	19	3	8-23	411
200	230	340	225	295	268	20	3	8-23	498
250	250	395	245	350	320	22	3	12-23	579
300	270	445	285	400	378	24.5	4	12-23	679

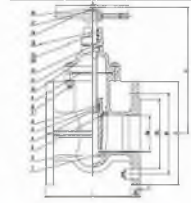

Nominal pressure(MPa)	1.0MPa
Suitable medium	Water oil products
Testing pressure (Mpa)	Body 1.5MPa
	Seat 1.1MPa
Working temperature(°C)	120°C

### Technical Requirements

- 1.Design & manufacture conform to DIN3352
- 2.Test & inspect conform to DIN3230,ISO 5208
- 3.Flange dimension conforms to EN1092-2 PN10
- 4.Face to face and end to end DIN3202 F4
- 5.Pressure-temperature ratings to DIN2401

## ► Rising gate valve



DN	L	H	D	D1	D2	b	n-d	W
50	150	347	165	125	102	20	4-18	180
65	170	390	185	145	122	20	4-18	180
80	180	470	200	160	138	22	8-18	200
100	190	535	220	180	158	24	8-18	200
125	200	644	250	210	188	26	8-18	250
150	210	739	285	240	212	26	8-22	280
200	230	936	340	295	268	28	8-22	300
250	250	1133	395	350	320	28	12-22	360
300	270	1330	445	400	370	28	12-22	400

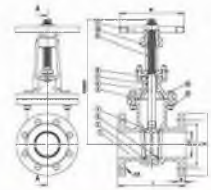

### PRESSURE TEST TO DIN 3230

DN	Pressure Rating(PN)	Hydro-Test Pressure(Mpa)	
		Body	Seat
50-300	10	1.5	1.1

- 1.Design according to: DIN3352
- 2.Face to face according to DIN3202 F4
- 3.Flange drilling according to: DIN2532 PN10
- 4.Testing according to: DIN 3230

## ► Non-rising gate valve



DN	L	H	D	D1	D2	b	n-d	W
40	240	195	150	110	88	18	4-18	160
50	250	202	165	125	102	20	4-18	160
65	270	222	185	145	122	20	4-18	160
80	280	250	200	160	138	22	8-18	160
100	300	303	220	180	158	24	8-18	200
125	325	351	250	210	188	26	8-18	250
150	350	411	285	240	212	26	8-22	250
200	400	498	340	295	268	28	12-22	250
250	450	579	405	355	320	28	12-26	320
300	500	679	460	410	378	28	12-26	320

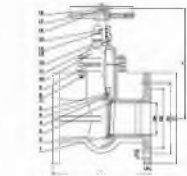

Nominal pressure(MPa)	1.6MPa
Suitable medium	Water oil products
Testing pressure (MPa)	Body 2.4MPa
	Seat 1.76MPa
Working temperature(°C)	120°C

### Technical Requirements

- 1.Design & manufacture conform to DIN3352
- 2.Test & inspect conform to DIN3230, ISO 5208
- 3.Flange dimension conforms to DIN2533 PN16
- 4.Face to face and end to end: DIN3202 F5
- 5.Pressure-temperature ratings to DIN2401

## ► Globe Valve

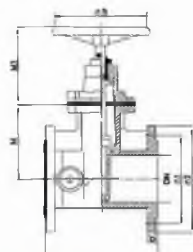

PN	DN	L	L <sub>1</sub>	D	D <sub>1</sub>	D <sub>2</sub>	B	f	H	N-Φ	ΔH (STROKE)
16	15	130	130	95	65	45	16	2	195	4-14	6
	20	150	150	105	75	58	18	2	195	4-14	6
	25	160	160	115	85	68	18	2	210	4-14	8
	32	180	180	140	100	78	18	2	210	4-18	8
	40	200	200	150	110	88	18	3	220	4-18	13
	50	230	230	165	125	102	20	3	225	4-18	13
	65	290	290	185	145	122	22	3	260	4-18	16
	80	310	310	200	160	138	22	3	280	8-18	20
	100	350	350	220	180	158	22	3	340	8-18	25
	125	400	400	250	210	188	24	3	360	8-18	32
	150	480	480	285	240	212	26	3	430	8-22	40
200	600	600	340	295	268	28	3	540	12-22	50	

## ► Welded Ball valve

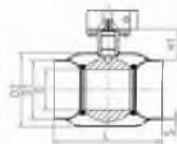

SIZE	PN	D	D1	D2	S	H	H1	A	L
1/2"	40	10	21.3	38	2.5	100	40	120	230
3/4"	40	15	26.9	42	2.5	100	40	120	230
1"	40	20	33.7	51	2.6	105	40	150	230
1 1/4"	40	25	42.4	57	3	105	40	150	260
1 1/2"	40	32	48.3	76	3	125	59	190	260
2"	40	40	60.3	88.9	3	130	59	190	300
2 1/2"	25	50	76.1	108	3	180	71	280	300
3"	25	65	88.9	127	4	190	77	280	300
4"	25	80	114.3	153	4	200	92	280	325
5"	25	100	139.7	177.8	4.5	245	95	420	325
6"	25	125	168.3	219.1	6	265	103	550	350
8"	25	150	219.1	273	6		115		400
10"	25	200	273	355.6	7		124		530
12"	25	250	323.9	457	8		155		550
24"	25	500	610	830	12.5		259		1067



## ► Flanged Ball Valve

Q41F-10  
16 (Z.Q.T.P.R.C)

1. Working temperature: ≤150°
2. Applicable media: Water, steam, oils and corrosive media.
3. The end of ball valve is flanged, which can be equipped with manually, electrically or pneumatically operated actuator in order to meet the different applications and control requirements
4. Nominal pressure: 1.6Mpa

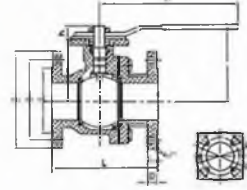

IN	ΦA	ΦB	ΦC	L	L1	H	E	D	F	ΦG1 / ΦG	h	Z-Φd
1/2"	95	65	45	115	130	49	80	11	2	F03/F04	9.5	4-Φ14
3/4"	105	75	58	120	130	54	80	11	2	F03/F04	9.5	4-Φ14
1"	115	85	68	125	170	60	90	13	2	F04/F05	11.5	4-Φ14
1-1/4"	140	100	78	130	170	73	102	14	2	F04/F05	15.5	4-Φ18
1-1/2"	150	110	88	140	220	78	110	14	3	F05/F07	15.5	4-Φ18
2"	165	125	102	150	220	86	120	14	3	F05/F07	15.5	4-Φ18
2-1/2"	185	145	122	170	284	98	140	17	3	F07/F10	18.5	4-Φ18
3"	200	160	138	180	284	113	150	17	3	F07/F10	18.5	8-Φ18
4"	220	180	160	190	380	136	180	17	3	F07/F10	18.5	8-Φ18
5"	250	210	188	200	447	165	215	17	3	F07/F10	18.5	8-Φ18
6"	285	240	212	210	560	190	240	17	3	F10/F12	23	8-Φ22
8"	340	295	268	400	1000	229	320	20	3	F12/F14	25	12-Φ22

## ► Rubber Expansion Joint

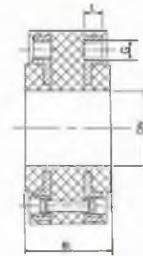

DN	BL	PRESSURE RATING MAX	DIN PN6 Flange to DIN PN6				DIN PN10 Flange to DIN PN10				WEIGHT
			FLANGE ΦD	BOLT CIRCLE ΦK	THICKNESS n×M×L	WEIGHT	FLANGE ΦD	BOLT CIRCLE ΦK	THICKNESS n×M×L		
20	70	10	90	65	4×M10×14	1.5	105	75	4×M12×12	2.0	
25	70	10	100	75	4×M10×16	1.9	115	85	4×M12×16	2.7	
32	70	10	120	90	4×M12×16	2.8	140	100	4×M12×16	4.1	
40	70	10	130	100	4×M12×16	3.0	150	110	4×M12×16	4.4	
50	70	10	140	110	4×M12×16	3.2	165	125	4×M12×16	5.1	
65	70	10	160	130	4×M12×16	4.0	185	145	4×M12×16	6.2	
80	70	10	190	150	4×M16×18	6.5	200	160	8×M12×18	7.5	
100	70	10	210	170	4×M16×18	6.9	220	180	8×M12×18	8.1	
125	70	10	240	200	8×M16×18	8.5	250	210	8×M12×18	9.4	
150	70	10	265	225	8×M16×18	9.4	285	240	8×M20×18	12.4	
200	90	10	320	280	8×M16×20	14.5	340	295	8×M20×20	18.8	

## ▶ Single Spherical Rubber Expansion Joints



GB										ANSI 15C											
Nominal core diameter DN		Length L (mm)	NO. of bolt n	Diameter of bolt hole center circle D1(mm)	Diameter of bolt hole center circle D2(mm)		Axial displacement (mm)		Lateral Displacement (mm)	Angle of deflection (°±2)	Nominal core diameter DN	Length L (mm)	h	NO Bolt n	Diameter of bolt hole d1(mm)	Diameter of bolt hole d2(mm)		Axial displacement (mm)		Lateral Displacement (mm)	Angle of deflection (°±2)
(mm)	(in.)				Stretch	Compression	Stretch (mm)	Compression													
32	1 1/4	95	4	17.5	100	8	8	9	15°	25	1	152	130	14	4	18	79.4	+9.5	-13	±13	±18°
40	1 1/2	95	4	17.5	110	8	10	9	15°	32	1 1/4	152	130	16	4	18	88	+9.5	-13	±13	±15°
50	2	105	4	17.5	125	7	10	10	15°	40	1 1/2	152	130	16	4	18	98.5	+9.5	-13	±13	±15°
65	2 1/2	115	4	17.5	145	7	13	11	15°	50	2	152	130	18	4	19	121	+9.5	-13	±13	±15°
80	3	125	6	17.5	160	8	15	12	15°	65	2 1/2	152	130	18	4	19	139.5	+9.5	-13	±13	±15°
100	4	150	8	17.5	180	10	19	13	15°	80	3	152	130	18	4	19	153	+9.5	-13	±13	±15°
125	5	165	8	17.5	210	12	19	14	15°	100	4	152	130	18	8	19	190	+9.5	-16	±13	±15°
140	5 1/2	180	8	22	240	12	20	22	15°	125	5	152	130	20	8	22.5	218	+9.5	-16	±13	±15°
200	8	190	200	8	22	295	16	25	22 15°	150	6	152	130	22	8	22.5	247	+9.5	-16	±13	±15°
250	10	230	240	12	22	350	16	25	22 15°	200	8	152	130	22	8	22.5	298	+9.5	-16	±13	±15°
300	12	245	280	12	22	400	16	25	22 15°	250	10	203	130	24	12	25.5	362	+13	-18	±19	±15°
350	14	265	18	26	460	16	25	22 15°	300	12	203	130	24	12	25.5	432	+13	-19	±19	±15°	
400	16	265	18	26	515	16	26	22 15°	350	14	203	200	26	12	28.5	476	+13	-19	±18	±15°	
450	18	265	20	28	565	16	25	22 15°	400	16	203	200	28	16	28.5	540	+13	-19	±16	±15°	
500	20	265	20	30	620	18	25	22 15°	450	18	203	200	30	18	32	578	+13	-19	±18	±15°	
600	24	265	20	28	725	18	25	22 15°	500	20	203	200	30	20	32	654	+13	-19	±18	±15°	
700	28	280	24	30	810	18	25	22 10°	600	24	254	260	32	20	35	749.5	+13	-19	±18	±15°	
800	32	280	24	30	920	18	25	22 10°	800	32	254	280	36	24	30		+13	-19	±19	±15°	
900	36	260	24	30	1020	18	25	22 10°													
1000	40	260	28	30	1120	18	25	22 10°													

## ▶ Double Spherical Rubber Expansion Joints

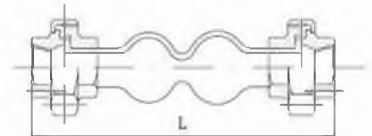

Table of Materials

Serial No.	Position	Material
1	Main body	Polarized rubber
2	Lining	Nylon cord fabric
3	Frame	Hard steel wire
4	Union	Forgeable cast iron

### Technical Specification

Working pressure	1.0MPa(10kgf/cm <sup>2</sup> )	Deflecting angle	(±1±2)45C
Bursting pressure	3.0MPa(30kgf/cm <sup>2</sup> )	Vacuity	53.3KPa(400mm Hg)
Applicable temp.	-20~+115C		
Applicable media	Air, Compressed air, water, sea water, hot water, weak acid, etc.		

Nominal core dia DN		L Value	Axial displacement (mm)		Lateral Displacement
(mm)	(in)		Stretch (mm)	Compression	
15	1/2	200	5-6	22	22
20	3/4	200	5-6	22	22
26	1	200	5-6	22	22
30	1 1/8	200	5-6	22	22
40	1 1/2	200	5-6	22	22
50	2	200	5-6	22	22
65	2 1/2	200	5-6	22	22
80	3	200	5-6	22	22

## ► Flanged Y-type strainer

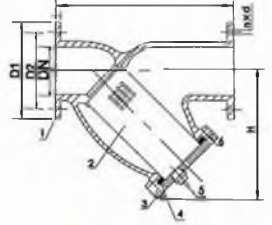

Item	Description	Materials	Remark
1	Body	GG25	GGG40
2	Strainer	SS304	1cr18Ni9Ti
3	Cover	GG25	
4	Washer	PTFE+Graphite	
5	Bolt	GG25	
6	Bolt	A3	

Performance and Size			
(Working media) Water, Steam, oil			
(Working pressure) PN10, PN16			
Examination pressure	sealing	10/16	temperature
	interruption	24	≤200°C

Shape and Joint dimensions							
PN	DN	D1	L	b	H	D2	n*d
10/16	40	φ150	200	18	126	φ110	4-φ18
	50	φ165	230	20	134	φ125	4-φ18
	65	φ185	290	20	182	φ145	4-φ18
	80	φ200	310	22	208	φ160	8-φ18
	100	φ220	350	24	240	φ180	8-φ18
	125	φ250	400	26	280	φ210	8-φ18
	150	φ285	480	26	325	φ240	8-φ22
	200	φ340	600	30	400	φ295	8-φ22/12-φ22
250	φ405	730		485	φ350/355	12-φ26	

## ► Y-STRAINER(ANSI 800PSI)

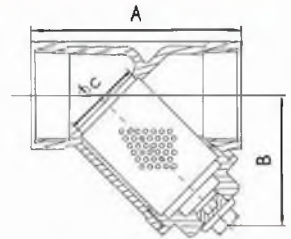

### PART LIST

Item	Designation	Material
1	BODY	CF8/CF8M
2	SCREEN	304
3	GASKET	PTFE
4	BONNET	CF8M

### DIMENSION TABLE

ITEM	SIZE							
	1/4"	3/8"	1/2"	3/4"	1"	1 1/4"	1 1/2"	2"
C	10	12	15	20	25	32	40	50
A	35	65	65	80	90	105	120	140
B	51	51	51	60	72	77	87	103



## ▶ 1-PC BALL VALVE

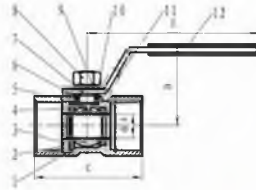

### SPECIFICATIONS

- ▶ Working Pressure:1000PSI
- ▶ Temperature Range:-40°C~232°C
- ▶ End Types:Female Threaded
- ▶ Options:Locking device
- ▶ Reduce Bore

NO.	PART NAME	MATERIAL
1	BODY	CF8M
2	BALL	SS316
3	END CAP	CF8M
4	STEM	SS304/SS316
5	THRUST WASHER	PTFE
6	STEM PACKING	PTFE
7	HANDLE	SS304
8	GLAND NUT	SS304/SS316
9	STEM WASHER	SS304
10	STEM NUT	SS304
11	LOCKING DEVICE	SS304
12	HANDLE COVER	PLASTIC

SIZE	A	C	D	W
1/4"	5	39	39	68
3/8"	7	44	39	68
1/2"	9.2	57	40	88
3/4"	12.5	59	45	88
1"	15	71	53	110
1-1/4"	20	78	58	110
1-1/2"	25	83	66	135
2"	32	100	72	135

## ▶ 2-PC BALL VALVE

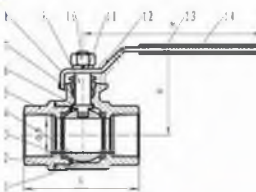

### SPECIFICATIONS

- ▶ Working Pressure:1000PSI
- ▶ Temperature Range:-40°C~232°C
- ▶ End Types:Female Threaded
- ▶ Options:Locking device
- ▶ Full Bore

NO.	PART NAME	MATERIAL
1	BODY	CF8M
2	BODY SEAL	PTFE
3	BALL SEAT	RP/TFE/PTFE
4	BALL	SS316
5	END CAP	CF8M
6	THRUST WASHER	PTFE
7	STEM PACKING	PTFE
8	GLAND NUT	SS304/SS316
9	STEM	SS304/SS316
10	STEM NUT	SS304
11	STEM WASHER	SS304
12	LOCKING DEVICE	SS304
13	HANDLE	SS304
14	HANDLE COVER	PLASTIC

SIZE	D	L	H	W
1/4"	11.5	51	50	110
3/8"	12.5	51	50	110
1/2"	15	57	53	110
3/4"	20	68	57	115
1"	25	80	65	125
1-1/4"	32	91	70	125
1-1/2"	38	103	85	155
2"	50	122	94	155
2-1/2"	65	159	115	225
3"	76	182	124	225
4"	94	224	150	300





### ▶ 3-PC BUTT WELD BALL VALVE

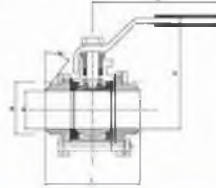

#### SPECIFICATIONS

- ▶ Working Pressure:1000PSI
- ▶ Temperature Range:-40°C~232°C
- ▶ End Types:Butt welded
- ▶ Options:Locking device
- ▶ Full Bore

SIZE	d	D	L	H	W
1/4"	11.5	16.4	65	50	110
3/8"	12.5	18	65	50	110
1/2"	15	22	66	53	110
3/4"	20	27	80	57	115
1"	25	33.5	85	65	125
1-1/4"	32	44	105	70	125
1-1/2"	38	50	113	85	155
2"	50	61.5	134	94	155
2-1/2"	65	75.4	170	115	225
3"	76	90	166	124	225
4"	94	114	220	150	300

### ▶ 3-PC THREADED BALL VALVE

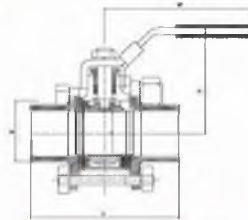

#### SPECIFICATIONS

- ▶ Working Pressure:1000PSI
- ▶ Temperature Range:-40°C~232°C
- ▶ End Types:Female Threaded
- ▶ Options:Locking device
- ▶ Full Bore

SIZE	d	L	H	B
1/4"	12.5	72	50	107
3/8"	12.5	72	50	107
1/2"	15	72	83	107
3/4"	20	80	58	125
1"	25	85	68	132
1-1/4"	32	105	73	145
1-1/2"	38	123	86	147
2"	50	134	93	163
2-1/2"	65	170	115	225
3"	76	186	124	225
4"	94	220	150	300

► PIPE FITTINGS(316/304 150PSI)

MH001



MH002



MH003



MH004



MH005



MH006



MH007



MH008



MH009



MH0010



MH0011



MH0012



MH0013



MH0014



MH0015



MH0016



MH0017



MH0018



► Description of product numbering method

MH0019



MH0020



MH0021



MH0022



MH0023



MH0024



MH0025



MH0026



MH0027

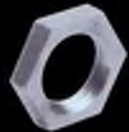

MH0028



MH0029



MH0030



MH0031



MH0032



MH0033



MH0034



MH0035



MH0036



## ▶ Worm Gear

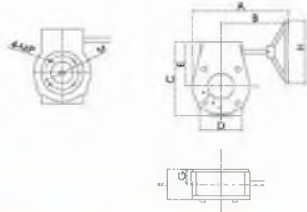

SIZE	2"-4"	5"-6"	8"-10"	12"-14"	16"	18"	20"	24"
Transfer Ratio	24:1	30:1	50:1	50:1	80:1		300:1	
Torque(Nm)	200	500	1200		2500		4000	
A	206	340	308		430		480	
B	154	233	226		300		350	
C	127	177	209		250		310	
D	105	154	184		260		276	
E	45	63	77.5		120		120	
F	65	77	77		103			
G	38	39	38		52.5		74.5	
ΦH	152	300	300		300		300/400	
ΦM	70	70	102/125	125	125	165	165	
4-MP	M8	M8	M10/M12	M12	M12	M18/M20	M18/M20	

## ▶ Screwing Gear

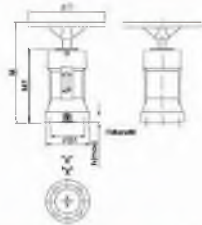

NO	Size	H	ΦD	ΦD1	H1	Φd1 x n x M	h	Weight(kg)
1	2"-4"	243	160	90	173	70x4xM6	32	7.0
2	5"-6"	252	160	90	162	70x4xM6	32	7.0
3	8"	320	200	125	264	102x4xM10	50	14.0
	300							
4	12"	320	300	150	254	125x4xM12	50	17.0

## ▶ Hand lever

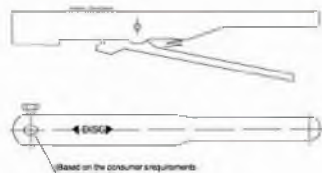

Архангельск (8182)63-90-72  
 Астана (7172)727-132  
 Астрахань (8512)99-46-04  
 Барнаул (3852)73-04-60  
 Белгород (4722)40-23-64  
 Брянск (4832)59-03-52  
 Владивосток (423)249-28-31  
 Волгоград (844)278-03-48  
 Вологда (8172)26-41-59  
 Воронеж (473)204-51-73  
 Екатеринбург (343)384-55-89  
 Иваново (4932)77-34-06

Ижевск (3412)26-03-58  
 Иркутск (395)279-98-46  
 Казань (843)206-01-48  
 Калининград (4012)72-03-81  
 Калуга (4842)92-23-67  
 Кемерово (3842)65-04-62  
 Киров (8332)68-02-04  
 Краснодар (861)203-40-90  
 Красноярск (391)204-63-61  
 Курск (4712)77-13-04  
 Липецк (4742)52-20-81  
 Киргизия (996)312-96-26-47

Магнитогорск (3519)55-03-13  
 Москва (495)268-04-70  
 Мурманск (8152)59-64-93  
 Набережные Челны (8552)20-53-41  
 Нижний Новгород (831)429-08-12  
 Новокузнецк (3843)20-46-81  
 Новосибирск (383)227-86-73  
 Омск (3812)21-46-40  
 Орел (4862)44-53-42  
 Оренбург (3532)37-68-04  
 Пенза (8412)22-31-16  
 Казахстан (772)734-952-31

Пермь (342)205-81-47  
 Ростов-на-Дону (863)308-18-15  
 Рязань (4912)46-61-64  
 Самара (846)206-03-16  
 Санкт-Петербург (812)309-46-40  
 Саратов (845)249-38-78  
 Севастополь (8692)22-31-93  
 Симферополь (3652)67-13-56  
 Смоленск (4812)29-41-54  
 Сочи (862)225-72-31  
 Ставрополь (8652)20-65-13  
 Таджикистан (992)427-82-92-69

Сургут (3462)77-98-35  
 Тверь (4822)63-31-35  
 Томск (3822)98-41-53  
 Тула (4872)74-02-29  
 Тюмень (3452)66-21-18  
 Ульяновск (8422)24-23-59  
 Уфа (347)229-48-12  
 Хабаровск (4212)92-98-04  
 Челябинск (351)202-03-61  
 Череповец (8202)49-02-64  
 Ярославль (4852)69-52-93

## ▶ Pneumatic Actuator

- Structure form: Double-piston gear-strip structure with steady output torque, single action plus spring, single and double action to the same cylinder body.
- Introduction of work: 2-10bar, filtrate dry or oiled lubricated compressed air.
- Working temperature: -20°C~+95°C; special temperature -50-180
- Angle of rotation: 90°, 120°, 180° can be chosen for standard type.
- Output torque: 3-80,000Nm (See torque meter)
- Connection mode: Installation hole at joint of bottom surface and valve rod is double four-square, tallying with standard of ISO5211/DIN3337S, tallying with NAMUR standard for air feed. It can be installed directly with electromagnetic valve.
- Material: Cylinder body: aluminum alloy+anodic treatment; End cover: aluminum alloy+epoxy resin treatment; Gear shaft steel+rigid inlaid electroplating coating decoration
- Bearing: Low friction material acetal resin; Sealing element: rubber BUNAN(VITON or EPDM)



SIZE(M)	Input air absolute pressure(BAR)									
	2	3	4	5	6	7	8	9	10	10
CT32	3.0	4.5	6.0	7.5	9.0	10.5	12	12.6	15	
CT45	6.0	9.0	12.0	15	18.0	21	24	27	30	
CT63	14.2	21.3	28.4	35.5	42.6	49.7	56.8	63.9	71	
CT83	30.4	45.6	60.8	76	91.2	106.4	121.6	136.8	152	
CT110	65.5	98.2	131	163.7	196.5	229	262	294	327	
CT127	102	153	205	256	307	358	410	461	512	
CT143	175	262	350	437	525	612	700	787	875	
CT160	267	400	534	667	801	934	1068	1201	1335	
CT210	498	747	996	1245	1494	1743	1992	2241	2490	
CT240	732	1098	1464	1830	2196	2562	2928	3294	3660	
CT270	1112	1668	2224	2780	3336	3892	4448	5004	5560	
CT300	1271	1906	2543	3177	3813	4448	5088	5718	6355	
CT330	2264	3426	4590	5710	6852	7994	9136	10278	11420	
CT400	3255	4885	6515	8137	9765	11392	13020	14647	16275	
CT500	8478	12717	16958	21195	25434	29673	33912	38151	42380	
CT800	18277	27415	36554	45692	54831	63969	73108	82246	91385	

## ▶ Clutch gear-operator

- This speed reduction unit is used in combination with pneumatic plant, used for butterfly valve, ball valve and plug valve, etc. with 90° unblocking degree to realize manual or pneumatic drive.



Model	Velocity ratio	Input torque moment Nm	Input torque moment Nm	diameter of handwheel	Weight(kg)
XLHJ26	26:1	60	300	200	7
XLHJ38A		60	500	200	
XLHJ38B	38.1	75	620	250	13
XLHJ38C		90	700	300	
		100	1000	250	
XLHJ54	54:1	120	1200	300	17
		110	1600	300	
XLHJ80	80:1	140	2000	400	22
		200	3100	600	
XLHJ78	78:1	200	3100	600	38

## ▶ Electric Actuator

