

Архангельск (8182)63-90-72
Астана (7172)727-132
Астрахань (8512)99-46-04
Барнаул (3852)73-04-60
Белгород (4722)40-23-64
Брянск (4832)59-03-52
Владивосток (423)249-28-31
Волгоград (844)278-03-48
Вологда (8172)26-41-59
Воронеж (473)204-51-73
Екатеринбург (343)384-55-89
Иваново (4932)77-34-06

Ижевск (3412)26-03-58
Иркутск (395)279-98-46
Казань (843)206-01-48
Калининград (4012)72-03-81
Калуга (4842)92-23-67
Кемерово (3842)65-04-62
Киров (8332)68-02-04
Краснодар (861)203-40-90
Красноярск (391)204-63-61
Курск (4712)77-13-04
Липецк (4742)52-20-81
Киргизия (996)312-96-26-47

Магнитогорск (3519)55-03-13
Москва (495)268-04-70
Мурманск (8152)59-64-93
Набережные Челны (8552)20-53-41
Нижний Новгород (831)429-08-12
Новокузнецк (3843)20-46-81
Новосибирск (383)227-86-73
Омск (3812)21-46-40
Орел (4862)44-53-42
Оренбург (3532)37-68-04
Пенза (8412)22-31-16
Казахстан (772)734-952-31

Пермь (342)205-81-47
Ростов-на-Дону (863)308-18-15
Рязань (4912)46-61-64
Самара (846)206-03-16
Санкт-Петербург (812)309-46-40
Саратов (845)249-38-78
Севастополь (8692)22-31-93
Симферополь (3652)67-13-56
Смоленск (4812)29-41-54
Сочи (862)225-72-31
Ставрополь (8652)20-65-13
Таджикистан (992)427-82-92-69

Сургут (3462)77-98-35
Тверь (4822)63-31-35
Томск (3822)98-41-53
Тула (4872)74-02-29
Тюмень (3452)66-21-18
Ульяновск (8422)24-23-59
Уфа (347)229-48-12
Хабаровск (4212)92-98-04
Челябинск (351)202-03-61
Череповец (8202)49-02-64
Ярославль (4852)69-52-93

<https://chpbv.nt-rt.ru/> || cph@nt-rt.ru

КАТАЛОГ



Butterfly Valve c/w Signal Gearbox – Wafer End

Technical Features

- Flange Standard: ANSI 125 / 150, DIN2501 PN10/16
- Connection: Wafer End
- Sizes: 2", 2½", 3", 4", 5", 6", 8", 10", 12"
- Approvals: UL, CUL, FM, NSF / ANSI 61 & NSF / ANSI 372
- Maximum Working Pressure: 300 PSI (Maximum Testing Pressure: 600 PSI) conforms to UL1091 & ULC / ORD-C1091 & FM 1112
- Maximum Working Temperature: 80°C / 176°F
- Application: Indoor & Outdoor Use, Fire inflow water, drain pipe, high-rising building fire fighting system, industrial factory building fire protection system
- Coating Details: Epoxy coated interior and exterior by Electrostatic Spray or coating upon request
- Disc: Ductile iron EPDM Rubber Encapsulated
- Top Flange Standard: ISO 5211
- Certified lead-free by NSF / ANSI 61 & NSF / ANSI 372 is available



Valve Material List

NO.	Description	Material	Standard
1	Upper Shaft Sealing Nut	WCB	ASTM A216
2	Shaft Seal	EPDM	ASTM D2000
3	Body	Ductile Iron	ASTM A536 Grade 65-45-12
4	Upper Shaft	416 Stainless Steel	ASTM A582
5	Disc+Rubber Seal	Ductile Iron+EPDM	ASTM A536+ASTM D2000
6	Lower Shaft	416 Stainless Steel	ASTM A582
7	Lower Shaft Sealing Nut	WCB	ASTM A216
8	End Face Seal	EPDM	ASTM D2000
9	Stem Bushing	PTFE / CR5400	
10	O-Ring	EPDM	ASTM D2000
11	Gearbox		

Dimensions

Size	A	B	C	D	H	K	J	P	M	N	d	L	
2"	110	85	32	100	111	153	218	152	90	70	9	10	42
2½"	125	95	32	112	111	153	218	152	90	70	9	10	44.2
3"	140	100	32	120	111	153	218	152	90	70	9	11	45.3
4"	160	100	32	181	111	153	218	152	90	70	9	14	52
5"	170	125	32	182	111	153	218	152	90	70	9	14	54.4
6"	190	140	32	216	111	153	218	200	90	70	9	16	55.8
8"	230	175	32	260	126	210	232	300	125	102	12	18	60.5
10"	260	200	45	320	126	210	232	300	125	102	12	24	66.5
12"	300	240	45	375	181	249	350	150	125	14	26	76.9	

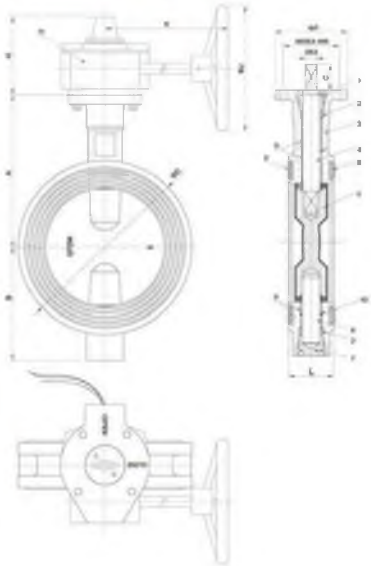

3D Pictures

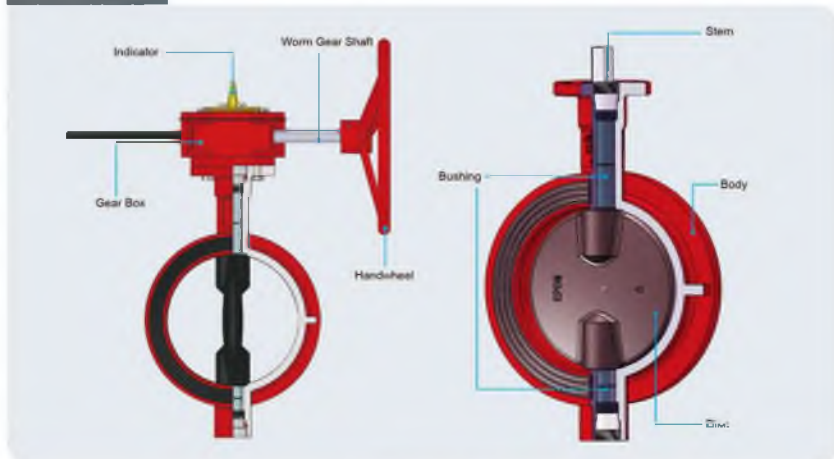

Gearbox Drawing

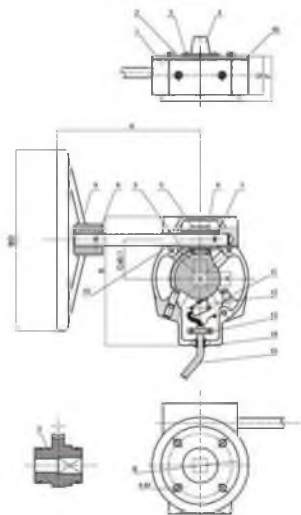

Gearbox Material List

NO	Description	Material	Standard
1	Gear Body	Ductile Iron	ASTM A536 Grade 65-45-12
2	Gear Cover	Ductile Iron	ASTM A536 Grade 65-45-12
3	Worm Wheel	Ductile Iron	ASTM A536 Grade 65-45-12
4	Indicator	Ductile Iron	ASTM A536 Grade 65-45-12
5	Worm	Steel	
6	Handwheel Shaft	Steel	
7	Pin	416 Stainless Steel	ASTM A582
8	Pin	416 Stainless Steel	ASTM A582
9	Handwheel	Ductile Iron	ASTM A536 Grade 65-45-12
10	O-Ring	EPDM	ASTM D2000
11	Set Screw	Steel	
12	Signal Switch	Switch Assembly	
13	Clip	Nylon	
14	Sealing Ring	EPDM	ASTM D2000
15	Wire	Wire	
16	Gasket	EPDM	ASTM D2000

Dimensions

Gearbox Valve	A	B	C	D	E	F	G	H	M	
24:1 2"-2 1/4"	153	218	184	45	152	70	65	58	10	M8
24:1 3"	153	218	184	45	152	70	65	58	11	M8
24:1 4"-5"	153	216	164	45	152	70	65	58	14	M8
24:1 6"	153	218	184	45	200	70	65	58	18	M8
30:1 6"	210	232	205	63	300	102	79	67	19	M10
30:1 10"	210	232	205	63	300	102	79	67	22	M10
80:1 12"	249	284	120	350	126	118	110	24	M12	

Butterfly Valve c/w Signal Gearbox – Grooved End

Technical Features

- Conforms: ANSI / AWWA C608 or Metric Standard Clear Waterway design
- Connection: Grooved End
- Sizes: 2", 2½", 3", 4", 5", 6", 8", 10", 12"
- Approvals: UL, CUL, FM, NSF / ANSI 61 & NSF / ANSI 372
- Maximum Working Pressure: 300 PSI (Maximum Testing Pressure: 600 PSI) conforms to UL1091 & ULC / ORD-C1091 & FM 1112
- Maximum Working Temperature: 80°C / 176°F
- Application: Indoor & Outdoor Use, Fire inflow water, drain pipe, high-rising building fire fighting system, industrial factory building fire protection system
- Coating Details: Epoxy coated interior and exterior by Electrostatic Spray or coating upon request
- Disc: Ductile Iron EPDM Rubber Encapsulated
- Top Flange Standard: ISO 5211
- Certified lead-free by NSF / ANSI 61 & NSF / ANSI 372 is available



Valve Material List

NO	Description	Material	Standard
1	Upper Shaft Sealing Nut	WCB	ASTM A216
2	Shaft Seal	EPDM	ASTM D2000
3	Body	Ductile Iron	ASTM A536 Grade 65-45-12
4	Upper Shaft	416 Stainless Steel	ASTM A582
5	Disc+Rubber Seal	Ductile Iron+EPDM	ASTM A536+ASTM D2000
6	Lower Shaft	416 Stainless Steel	ASTM A582
7	Lower Shaft Sealing Nut	WCB	ASTM A216
8	Stem Bushing	PTFE / C95400	
9	O-Ring	EPDM	ASTM D2000
10	Gearbox		

Dimensions

Size	A	B	C	D	E	F	G	H	K	J	P	M	N	d	L	
2"	110	65	32	60.3	57.15	15.9	7.9	111	153	218	152	90	70	9	18	81 86
2½"	125	65	32	73	69.1	15.9	7.9	111	153	218	152	90	70	8	10	96.4
3"	140	100	32	89.9	84.9	15.9	7.9	111	153	218	152	90	70	9	11	97
4"	160	100	32	114.3	110.1	15.9	9.5	111	153	218	152	90	70	9	14	115.1 132.4
5"	170	125	32	137	135.5	15.9	9.5	111	153	218	152	90	70	8	14	168
6"	190	140	32	165.1	160.9	15.9	9.5	111	153	218	200	90	70	9	16	132.4 148
8"	230	175	32	219.1	214.4	18	11.1	126	210	232	300	125	102	12	19	133 147.4
10"	260	200	45	273	268.3	19	12.7	126	210	232	300	125	102	12	24	159
12"	300	240	45	318.5	312.9	18	12.7	161	249	350	150	125	14	26	165	

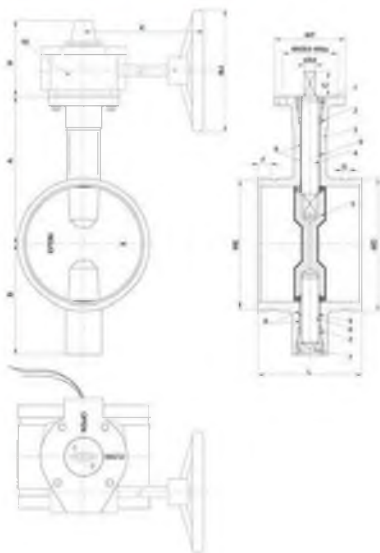

3D Pictures

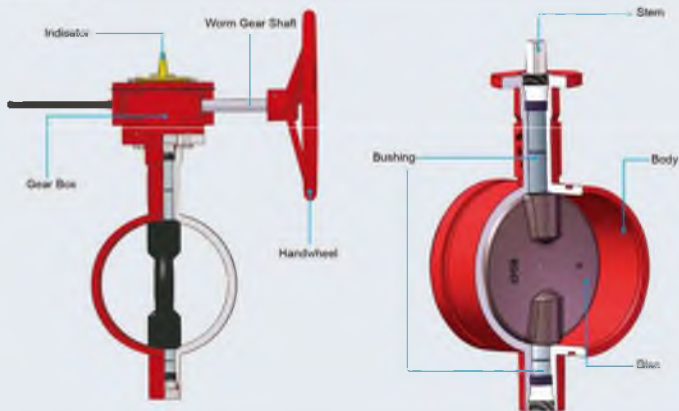

Gearbox Drawing

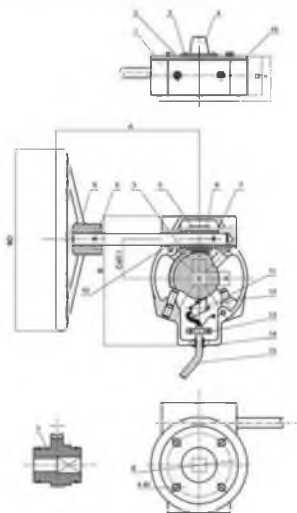

Gearbox Material List

NO	Description	Material	Standard
1	Gear Body	Ductile Iron	ASTM A538 Grade 65-45-12
2	Gear Cover	Ductile Iron	ASTM A536 Grade 65-45-12
3	Worm Wheel	Ductile Iron	ASTM A538 Grade 65-45-12
4	Indicator	Ductile Iron	ASTM A536 Grade 65-45-12
5	Worm	Steel	
6	Handwheel Shaft	Steel	
7	Pin	416 Stainless Steel	ASTM A582
8	Pin	416 Stainless Steel	ASTM A582
9	Handwheel	Ductile Iron	ASTM A536 Grade 65-45-12
10	O-Ring	EPDM	ASTM D2000
11	Set Screw	Steel	
12	Signal Switch	Switch Assembly	
13	Clip	Nylon	
14	Sealing Ring	EPDM	ASTM D2000
15	Wire	Wire	
16	Gasket	EPDM	ASTM D2000

Dimensions

Gearbox	Valve	A	B	C	D	E	F	G	H	I
24:1	2"-2½"	153	218	164	45	152	70	65	58	10
24:1	3"	153	218	164	45	152	70	65	58	11
24:1	4"-5"	153	218	164	45	152	70	65	58	14
24:1	6"	153	218	164	45	200	70	65	58	16
30:1	8"	210	232	205	63	300	102	79	67	19
30:1	10"	210	232	205	63	300	102	79	67	22
80:1	12"	249	284	120	350	125	118	110	24	M12

Backflow Butterfly Valve Model: HGD-381X-175/HFGD-381X-175/HGD-381X/HFGD-381X

Butterfly Valve c/w Signal Gearbox – Grooved End & Grooved + Flanged End

Technical Features

- Conforms: ANSI / AWWA C608 or Metric Standard Clear Waterway design
- Connections: Grooved End / Grooved + Flanged End / Flanged + Grooved End
- Sizes: 2½", 3", 4", 6", 8", 10"
- Approvals: UL, CUL, FM, NSF/ ANSI 61 & NSF/ ANSI 372
- Maximum Working Pressure: 175 PSI / 300 PSI (Maximum Testing Pressure: 600 PSI) conforms to UL1091 & ULC / ORD-C1091 & FM1112
- Maximum Working Temperature: 80°C / 176°F
- Application: Indoor & Outdoor Use, Fire inflow water, drain pipe, high-rising building fire fighting system, industrial factory building fire protection system
- Coating Details: Epoxy coated interior and exterior by Electrostatic Spray or coating upon request
- Disc: Ductile Iron EPDM Rubber Encapsulated
- Top Flange Standard: ISO 5211
- Certified lead-free by NSF/ANSI 61 & NSF/ANSI 372 is available



Valve Material List

NO.	Description	Material	Standard
1	Upper Shaft Sealing Nut	WCB	ASTM A216
2	Shaft Seal	EPDM	ASTM D2000
3	Body	Ductile Iron	
4	Upper Shaft	416 Stainless Steel	ASTM A582
5	Disc+Rubber Seat	Ductile Iron+EPDM	ASTM A536+ASTM D2000
6	Lower Shaft	416 Stainless Steel	ASTM A582
7	Lower Shaft Sealing Nut	WCB	ASTM A216
8	Stem Bushing	PTFE / C95400	ASTM B148
9	Signal Gearbox		
10	Plug	C85400	ASTM B148

Dimensions

Size	A	B	C	D	E	F	G	H	K	J	L	M	N	P
2½"	125	95	32	75	69.1	15.9	7.9	111	153	152	192.4	139.7	4	19
					76.1	72.3								
3"	140	100	32	89.9	84.9	15.9	7.9	111	153	152	198.8	152.5	4	19
4"	160	100	32	114.3	110.1	15.5	9.5	111	153	152	188.4	190.5	8	19
6"	190	140	32	165.1	160.9	15.9	9.5	111	153	200	177.6	241.3	8	22
				168.3	164									
8"	230	175	32	219.1	214.4	19	11.1	126	230	290	203	296.5	8	22
				216.3	211.6									
				267.4	262.6									
10"	260	200	45	273	268.3	19	12.7	126	230	290	303	362	12	25.4

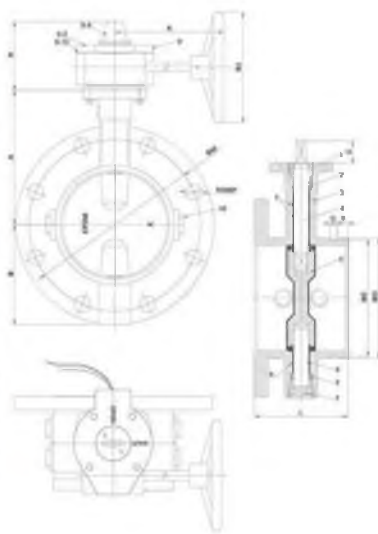

Butterfly Valve with Gearbox / Lever – Wafer End

Technical Features

- Flange Standard: ANSI 125 / 150, DIN2501 PN10 / 16
- Connection: Wafer End
- Sizes: 2", 2½", 3", 4", 5", 6", 8", 10", 12"
- Maximum Working Pressure: 300 PSI (Maximum Testing Pressure: 600 PSI) conforms to UL1091 & ULC / ORD-C1091 & FM 1112
- Maximum Working Temperature: 80°C / 176°F
- Application: Indoor & Outdoor Use, Fire inflow water, drain pipe, high-rising building fire fighting system, industrial factory building fire protection system
- Coating Details: Epoxy coated interior and exterior by Electrostatic Spray or coating upon request
- Disc: Ductile Iron EPDM Rubber Encapsulated
- Top Flange Standard: ISO 5211
- Certified lead-free by NSF / ANSI 61 & NSF / ANSI 372 is available



Valve Material List

NO	Description	Material	Standard
1	Upper Shaft Sealing Nut	WCB	ASTM A216
2	Shaft Seal	EPDM	ASTM D2000
3	Body	Ductile Iron	ASTM A536 Grade 65-45-12
4	Upper Shaft	416 Stainless Steel	ASTM A582
5	Disc+Rubber Seal	Ductile Iron+EPDM	ASTM A536+ASTM D2000
6	Lower Shaft	416 Stainless Steel	ASTM A582
7	Lower Shaft Sealing Nut	WCB	ASTM A216
8	End Face Seal	EPDM	ASTM D2000
9	Stem Bushing	PTFE / C95400	
10	O-ring	EPDM	ASTM D2000
11	Lever		
12	Gearbox		

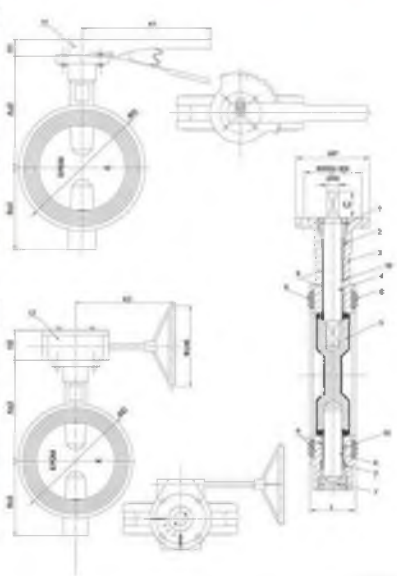

Dimensions

Size	A	B	C	D	H1	H2	K1	K2	J	P	M	N	d	L
2"	110	85	32	100	32	65	267	151	152	90	70	9	10	42
2½"	125	95	32	112	32	65	267	151	152	90	70	9	10	44.2
3"	140	100	32	120	32	65	267	151	152	90	70	9	11	45.3
4"	160	100	32	161	32	65	267	151	152	90	70	9	14	52
5"	170	125	32	182	32	65	267	151	152	90	70	8	14	54.4
6"	190	140	32	216	32	65	267	146	200	90	70	9	16	55.8
8"	230	175	32	260	37	77	267	233	290	125	102	12	19	60.5
10"	260	200	45	320	/	77	/	233	290	125	102	12	22	66.5
12"	300	240	45	375	/	77	/	226	290	150	125	14	26	76.9

Butterfly Valve with Gearbox – Grooved End

Technical Features

- Conforms: ANSI / AWWA C606 or Metric Standard Clear Waterway design
- Connection: Grooved End
- Sizes: 2", 2½", 3", 4", 5", 6", 8", 10", 12"
- Maximum Working Pressure: 300 PSI (Maximum Testing Pressure: 600 PSI) conforms to UL1091 & ULC / ORD-C1091 & FM 1112
- Maximum Working Temperature: 80°C / 176°F
- Application: Indoor & Outdoor Use, Fire inflow water, drain pipe, high-rising building fire fighting system, industrial factory building fire protection system
- Coating Details: Epoxy coated interior and exterior by Electrostatic Spray or coating upon request
- Disc: Ductile Iron EPDM Rubber Encapsulated
- Top Flange Standard: ISO 5211
- Certified lead-free by NSF / ANSI 61 & NSF / ANSI 372 is available



Valve Material List

NO	Description	Material	Standard
1	Upper Shaft Sealing Nut	WCB	ASTM A216
2	Shaft Seal	EPDM	ASTM D2000
3	Body	Ductile Iron	ASTM A536 Grade 65-45-12
4	Upper Shaft	416 Stainless Steel	ASTM A582
5	Disc+Rubber Seat	Ductile Iron+EPDM	ASTM A536+ASTM D2000
6	Lower Shaft	416 Stainless Steel	ASTM A582
7	Lower Shaft Sealing Nut	WCB	ASTM A216
8	Stem Bushing	PTFE / C95400	
9	O-Ring	EPDM	ASTM D2000
10	Gear box		

Dimensions

Size	A	B	C	D	E	F	G	H	K	J	P	M	N	d	L
2"	110	85	32	60.3	57.15	15.9	7.9	65	151	152	90	70	9	10	81.66
2½"	125	95	32	73	69.1	15.9	7.9	85	151	152	90	70	9	10	96.4
3"	140	100	32	89.9	84.9	15.9	7.9	65	151	152	90	70	9	11	97
4"	160	100	32	114.3	110.1	15.9	9.5	65	151	152	90	70	9	14	115.1
5"	170	125	32	135.7	133.5	15.9	9.5	65	151	152	90	70	9	14	132.4
6"	180	140	32	155.1	150.9	15.9	9.5	85	146	200	90	70	9	16	148
8"	230	175	32	219.1	214.4	19	11.1	77	233	290	125	102	12	19	173
10"	260	200	45	267.4	262.6	19	12.7	77	233	290	125	102	12	22	196
12"	300	240	45	323.8	318.3	19	12.7	77	226	290	150	125	14	26	165

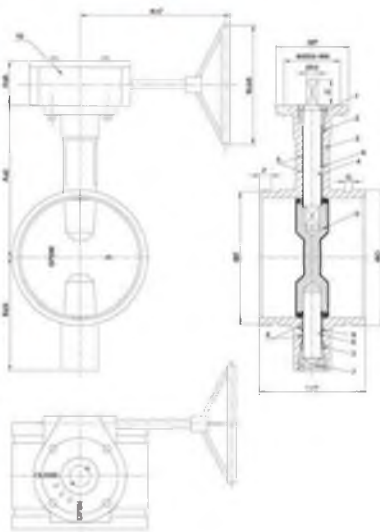

Butterfly Valve with Lever - Grooved End

Technical Features

- Conforms: ANSI / AWWA C608 or Metric Standard Clear Waterway design
- Connection: Grooved End
- Sizes: 2", 2½", 3", 4", 5", 6", 8"
- Maximum Working Pressure: 300 PSI (Maximum Testing Pressure: 600 PSI) conforms to UL1091 & ULC / ORD-C1091 & FM 1112
- Maximum Working Temperature: 80°C / 176°F
- Application: Indoor & Outdoor Use, Fire inflow water, drain pipe, high-rising building fire fighting system, industrial factory building fire protection system
- Coating Details: Epoxy coated interior and exterior by Electrostatic Spray or coating upon request
- Disc: Ductile Iron EPDM Rubber Encapsulated
- Top Flange Standard: ISO 5211
- Certified lead-free by NSF/ ANSI 61 & NSF/ ANSI 372 is available



Valve Material List

NO	Name	Material	Standard
1	Upper Shaft Sealing Nut	WCB	ASTM A216
2	Shaft Seal	EPDM	ASTM D2000
3	Body	Ductile Iron	ASTM A536 Grade 65-45-12
4	Upper Shaft	416 Stainless Steel	ASTM A582
5	Disc-Rubber Seat	Ductile Iron-EPDM	ASTM A536-ASTM D2000
6	Lower Shaft	416 Stainless Steel	ASTM A582
7	Lower Shaft Sealing Nut	WCB	ASTM A216
8	Stem Bushing	PTFE / C95400	
9	O-ring	EPDM	ASTM D2000
10	Lever	Malleable Iron	

Dimensions

Size	A	B	C	D	E	F	G	H	R	P	M	N	d	L
2"	110	85	32	60.3	57.2	15.9	7.9	32	267	90	70	9	8	88
2½"	125	95	32	73	69.1	15.9	7.9	32	267	90	70	9	10	98.4
3"	140	100	32	83.9	84.9	15.9	7.9	32	267	90	70	9	11	97
4"	180	100	32	114.3	110.1	15.9	9.5	32	267	90	70	9	14	115.1
5"	170	125	32	138.7	135.5	15.9	9.5	32	267	90	70	9	14	132.4
6"	190	140	32	155.1	150.9	15.9	9.5	32	267	90	70	9	16	148
8"	230	175	37	216.3	211.6	19	11.1	37	353	125	102	12	19	147.4
				219.1	214.4									133

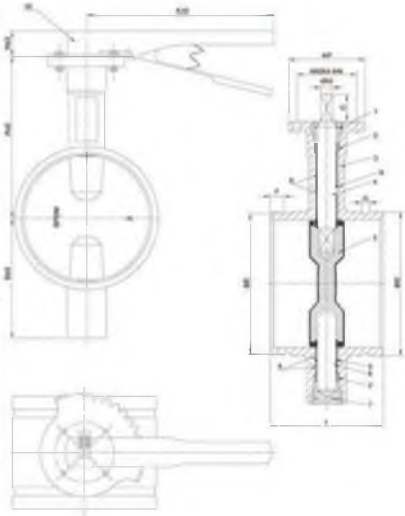

NINGJIN APC INDUSTRIES CO.,LTD.offers a complete package of resilient wedge gate valve with excellent Ductile Iron structure and stable sealing capability and popular end connection options

APC Resilient Wedge Gate Valve Features

- Conforms: ANSI / AWWA C515
- Approvals: UL, CUL, FM, NSF/ANSI 61 & NSF/ANSI 372 Certified lead-free
- Maximum Working Temperature: 80°C / 176°F
- Coating: Epoxy coated interior and exterior by Electrostatic Spray or Coating upon request

Application

- Outdoor and Indoor Fire inflow water, water supply and drainage, potable water, high-rising building fire fighting system, industrial factory building fire protection system.
- All OS&Y gate valves have tamper resistant handwheel nuts as well as pre-grooved stems enabling seamless tamper switch installation.
- All NRS gate valves are available with operated nut installed with vertical indicator post and wall type indicator.

Advantages

- Valve body, bonnet, disc, gland, & operating nut are all produced with ductile iron material with superior strength-to-weight ratios to guarantee high quality.
- Long service life with resilient seat cycling test at least 5000 times.
- The bottom of gate valve adopt straight-through design, no foreign matter store to make sure smooth flow and reliable sealing.
- Self-sealing design between the bonnet and body make the sealing more tight when pressure is higher within the allowable range.
- Multiple O-ring sealing structure to protect the stem under pressure during operation and maintenance , it causes no damage to the operator.

A full range UL/FM Gate Valves to meet customers' different requirements

- UL/FM OS&Y Gate valve (200psi & 300psi)
- Flange x Flange
- Flange x Groove
- Groove x Groove
- UL/FM NRS Gate valve (200psi & 300psi)
- Flange x Flange
- Flange x Groove
- Groove x Groove
- MJ x MJ
- MJ x Flange

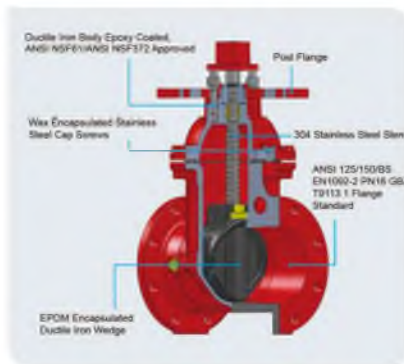
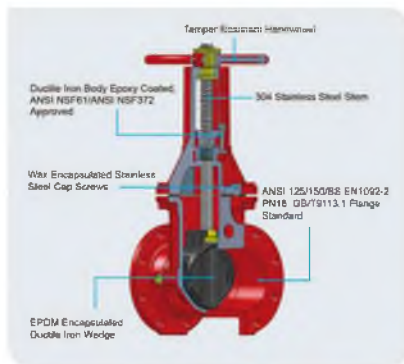

UL / FM OS&Y Gate Valves



Z41
Flange
ANSI, BS, DIN, GB
2"/DN50-16"/DN400
14Bar/200psi
UL/FM/NSF61/NSF372



Z481
Flange x Groove
ANSI, BS, DIN, GB
2"/DN50-12"/DN300
14Bar/200psi
UL/FM/NSF61/NSF372



Z81
Groove
ANSI, BS, DIN, GB
2"/DN50-12"/DN300
14Bar/200psi
UL/FM/NSF61/NSF372



Z41-300
Flange
ANSI, BS, DIN, GB
2 1/2"/DN65-12"/DN300
21Bar/300psi
UL/FM/NSF61/NSF372



Z41-300A
Flange
ANSI, BS, DIN, GB
2 1/2"/DN65-12"/DN300
21Bar/300psi
UL/FM/NSF61/NSF372



Z81-300
Groove
ANSI, BS, DIN, GB
2 1/2"/DN65-12"/DN300
21Bar/300psi
UL/FM/NSF61/NSF372



Z81-300A
Groove
ANSI, BS, DIN, GB
2 1/2"/DN65-12"/DN300
21Bar/300psi
UL/FM/NSF61/NSF372



Z481-300
Flange X Groove
ANSI, BS, DIN, GB
2 1/2"/DN65-12"/DN300
21Bar/300psi
UL/FM/NSF61/NSF372



Z481-300A
Flange X Groove
ANSI, BS, DIN, GB
2 1/2"/DN65-12"/DN300
21Bar/300psi
UL/FM/NSF61/NSF372

UL / FM Non Rising Stem Gate Valves



Z45
Flange
ANSI, BS, DIN, GB
2"/DN50-12"/DN300
14Bar/200psi
UL/FM/NSF61/NSF372



Z485
Flange X Groove
ANSI, BS, DIN, GB
2"/DN50-12"/DN300
14Bar/200psi
UL/FM/NSF61/NSF372



Z85
Groove
ANSI, BS, DIN, GB
2"/DN50-12"/DN300
14Bar/200psi
UL/FM/NSF61/NSF372



Z45-300
Flange
ANSI, DIN, GB
2 1/2"/DN65-12"/DN300
21Bar/300psi
UL/FM/NSF61/NSF372



Z45-300A
Flange
ANSI, DIN, GB
2"/DN50-12"/DN300
21Bar/300psi
UL/FM/NSF61/NSF372



Z85-300
Groove
ANSI, DIN, GB
2 1/2"/DN65-12"/DN300
21Bar/300psi
UL/FM/NSF61/NSF372



Z85-300A
Groove
ANSI, DIN, GB
2 1/2"/DN65-12"/DN300
21Bar/300psi
UL/FM/NSF61/NSF372



Z485-300
Flange X Groove
ANSI, DIN, GB
2 1/2"/DN65-12"/DN300
21Bar/300psi
UL/FM/NSF61/NSF372



Z485-300A
Flange X Groove
ANSI, DIN, GB
2 1/2"/DN65-12"/DN300
21Bar/300psi
UL/FM/NSF61/NSF372



Z45-300FJA
Flange X MJ
ANSI, DIN, GB
2"/DN50-12"/DN300
21Bar/300psi
UL/FM/NSF61/NSF372



Z45-300MJA
MJ X MJ
ANSI, DIN, GB
2"/DN50-12"/DN300
21Bar/300psi
UL/FM/NSF61/NSF372

Resilient Wedge OS & Y Gate valve – Flanged End

Technical Features

- Nominal Pressure: 300PSI
- Flange Standard: ASME / ANSI B 16.1 Class 125 or ASME / ANSI B 16.42 Class 150 or BS EN 1092-2 PN 16 or GB / T9113.1
- Sizes: 2½", 3", 4", 5", 6", 8", 10", 12"
- Face to Face Standard : ASME B 16.10
- Approvals: UL, CUL, FM, NSF / ANSI 61 & NSF / ANSI 372, CCC
- Maximum Working Pressure: 300PSI (Maximum Testing Pressure: 600 PSI) conforms to UL 262, ULC / ORD C 262-92 , FM 1120 / 1130
- Maximum Working Temperature: 80°C / 176°F
- Coating Details: Epoxy coated interior and exterior by Electrostatic Spray or Coating upon request
- NPT plug on body with 2 operating nuts
- Certified lead-free by NSF / ANSI 61 & NSF / ANSI 372 is available



Valve Material List

NO	Name	Material	Standard
1	Gasket	C95400	ASTM B148
2	Bonnet	Ductile Iron	ASTM A536 Grade 65-45-12
3	Packing	Graphite	
4	Disc	Ductile Iron +EPDM	ASTM A536 Grade 65-45-12-ASTM D2000
5	Body	Ductile Iron	ASTM A536 Grade 65-45-12
6	Sealing Ring	EPDM	ASTM D2000
7	Bolt	Steel 1045	ASTM A29
8	Gland	Ductile Iron	ASTM A536 Grade 65-45-12
9	Nut	Steel 1045	ASTM A29
10	Flat Washer	Steel 1045	ASTM A29
11	Bolt	Steel 1045	ASTM A29
12	Handwheel	Ductile Iron	ASTM A536 Grade 65-45-12
13	Lock Nut	C95400	ASTM B148
14	Locating Screw	Stainless Steel 304	ASTM A276
15	Stem	Stainless Steel 304	ASTM A276
16	Stem Nut	C95400	ASTM B148
17	Plug	C95400	ASTM B148
18	Lifting Nut	CF8	ASTM A351
19	Pin	Stainless Steel 304	ASTM A276
20	Sealing Ring	EPDM	ASTM D2600

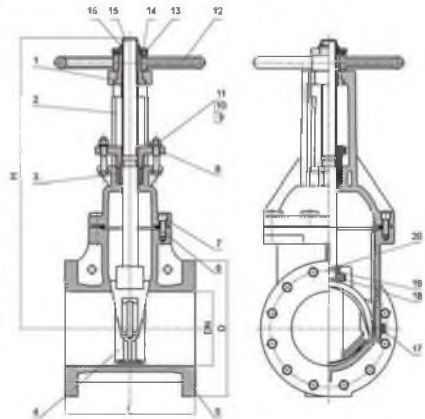

Dimensions

Size	DN	L	D	H
2½"	65	190	178	370
3"	80	203	191	420
4"	100	229	229	447
5"	125	254	254	547
6"	150	267	279	607
8"	200	292	343	754
10"	250	330	406	890
12"	300	356	483	1031

Resilient Wedge OS & Y Gate valve – Grooved End

Technical Features

- Nominal Pressure: 300PSI
- Groove standard: Metric or ANSI / AWWA C606
- Face to Face Standard: ASME B16.10
- Sizes: 2½", 3", 4", 5", 6", 8", 10", 12"
- Approvals: UL, CUL, FM, NSF / ANSI 61 & NSF / ANSI 372
- Maximum Working Pressure: 300PSI (Maximum Testing Pressure: 600 PSI) conforms to UL 262, ULC / ORD C 262-92, FM 1120 / 1130
- Maximum Working Temperature: 80°C / 176°F
- Coating Details: Epoxy coated interior and exterior by Electrostatic Spray or Coating upon request
- NPT plug on body with 2 operating nuts
- Certified lead-free by NSF / ANSI 61 & NSF / ANSI 372 is available

Valve Material List

ID	Name	Material	Standard
1	Gasket	Stainless Steel 304 or C95400	ASTM B148
2	Bonnet	Ductile Iron	ASTM A536 Grade 65-45-12
3	Packing	Graphite	
4	Disc	Ductile Iron + EPDM	ASTM A536 Grade 65-45-12/ASTM D2000
5	Body	Ductile Iron	ASTM A536 Grade 65-45-12
6	Sealing Ring	EPDM	ASTM D2000
7	Bolt	Stainless Steel 304 or Steel 1045	ASTM A29
8	Gland	Ductile Iron	ASTM A536 Grade 65-45-12
9	Nut	Stainless Steel 304 or Steel 1045	ASTM A29
10	Flat Washer	Stainless Steel 304 or Steel 1045	ASTM A29
11	Bolt	Stainless Steel 304 or Steel 1045	ASTM A29
12	Handwheel	Ductile Iron	ASTM A536 Grade 65-45-12
13	Lock Nut	C95400	ASTM B148
14	Locating Screw	Stainless Steel 304 or Steel 1045	ASTM A276
15	Stem	Stainless Steel 304 or C65400	ASTM A276
18	Stem Nut	C95400	ASTM B148
17	Plug	C95400	ASTM B148
18	Lifting Nut	CF8/CF8M or C65400	ASTM A351
19	Pin	Stainless Steel 304	ASTM A276
20	Sealing Ring	EPDM	ASTM D2000

Dimensions

Size	DN	L	F	D	E	G	H
2½"	65	190	15.9	73 76.1	69.1 72.3	7.9	370
3"	80	203	15.9	88.9	84.8	7.9	420
4"	100	229	15.9	114.3	110.1	9.5	447
5"	125	254	15.9	139.7 141.3	135.5 137	9.5	547
6"	150	267	15.9	165.1 168.3	160.8 163.9	9.5	607
8"	200	292	19	216.3 219.1	211.8 214.3	11.1	754
10"	250	330	19	273	268.3	12.7	890
12"	300	356	19	323.9	318.3	12.7	1031

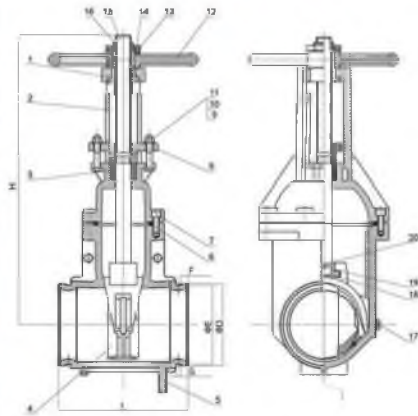

Resilient Wedge OS & Y Gate valve – Flanged x Grooved End

Technical Features

- Nominal Pressure: 300PSI
- Face to Face Standard: ASME B16.10
- Sizes: 2½", 3", 4", 5", 6", 8", 10", 12"
- Flange Standard: ASME / ANSI B16.1 Class 125 or ASME / ANSI B16.42 Class 150 or BS EN1092-2 PN16 or GB / T9113.1
- Groove Standard: Metric or ANSI / AWWA C606
- Approvals: UL, CUL, FM, NSF / ANSI 61 & NSF / ANSI 372
- Maximum Working Pressure: 300PSI (Maximum Testing Pressure: 600 PSI) conforms to UL262, ULC / ORD C262-92, FM 1120 / 1130
- Maximum Working Temperature: 80°C / 176°F
- Coating Details: Epoxy coated interior and exterior by Electrostatic Spray or Coating upon request
- NPT plug on body with 2 operating nuts
- Certified lead-free by NSF / ANSI 61 & NSF / ANSI 372 is available

Valve Material List

NO	Name	Material	Standard
1	Gasket	Stainless Steel 304 or C95400	ASTM A278 or ASTM B148
2	Bonnet	Ductile Iron	ASTM A536 Grade 65-45-12
3	Packing	Graphite	
4	Disc	Ductile Iron +EPDM	ASTM A536 Grade 65-45-12/ASTM D2000
5	Body	Ductile Iron	ASTM A536 Grade 65-45-12
6	Sealing Ring	EPDM	ASTM D2000
7	Bolt	Stainless Steel 304 or Steel 1045	ASTM A278 or ASTM A29
8	Clend	Ductile Iron	ASTM A536 Grade 65-45-12
9	Nut	Stainless Steel 304 or Steel 1045	ASTM A278 or ASTM A29
10	Flat Washer	Stainless Steel 304 or Steel 1045	ASTM A278 or ASTM A29
11	Bolt	Stainless Steel 304 or Steel 1045	ASTM A278 or ASTM A29
12	Handyheel	Ductile Iron	ASTM A536 Grade 65-45-12
13	Lock Nut	C95400	ASTM B148
14	Locating Screw	Stainless Steel 304 or Steel 1045	ASTM A278 or ASTM A29
15	Stern	Stainless Steel 304 or C95400	ASTM A278 or ASTM B148
16	Stem Nut	C95400	ASTM B148
17	Plug	C95400	ASTM B148
18	Lifting Nut	CF8 or C95400	ASTM A351 or ASTM B148
19	Pin	Stainless Steel 304	ASTM A276
20	Sealing Ring	EPDM	ASTM D2000

Dimensions

Size	DN	L	D	F	D2	E	G	H
2½"	65	190	178	15.9	73	89.1	7.9	370
3"	80	203	191	15.9	76.1	72.3	7.9	420
4"	100	229	229	15.9	95.9	94.9	9.5	447
5"	125	254	254	15.9	139.7	135.5	9.5	547
6"	150	287	279	15.9	141.3	137	9.5	607
					165.1	160.8		
8"	200	292	343	19	168.3	163.9	11.1	754
					219.1	214.3		
10"	250	330	408	19	273	268.3	12.7	890
12"	300	356	483	19	323.9	316.3	12.7	1031

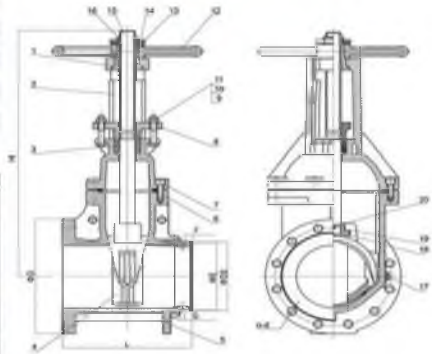

Resilient Wedge NRS Gate valve – Flanged End

Technical Features

- Nominal Pressure: 300PSI
- Flange Standard: ASME / ANSI B16.1 Class 125 or ASME / ANSI B16.42 Class 150 or BS EN1092-2 PN16 or GB / T9113.1
- Sizes: 2½", 3", 4", 5", 6", 8", 10", 12"
- Face to Face Standard: ASME B16.10
- Approvals: UL, CUL, FM, NSF / ANSI 61 & NSF / ANSI 372, CCC
- Maximum Working Pressure: 300PSI (Maximum Testing Pressure: 600PSI) conforms to UL262, ULC / ORD C262-92 , FM 1120 / 1130
- Maximum Working Temperature: 80°C / 176°F
- Coating Details: Epoxy coated interior and exterior by Electrostatic Spray or Coating upon request
- NPT plug on body with 2 operating nuts
- Certified lead-free by NSF / ANSI 61 & NSF / ANSI 372 is available



Valve Material List

NO	Name	Material	Standard
1	Flat Washer	Steel 1045 or Stainless Steel 304	ASTM A29 or ASTM A276
2	Inner Hexagon Screw	Steel 1045 or Stainless Steel 304	ASTM A29 or ASTM A276
3	Sealing Gland	EPDM	ASTM D2000
4	O-Ring	EPDM	ASTM D2000
5	Sealing Ring	EPDM	ASTM D2000
6	O-Ring	EPDM	ASTM D2000
7	Bonnet	Ductile Iron	ASTM A536 Grade 65-45-12
8	Stem	Stainless Steel 304	ASTM A276
9	Disc	Ductile Iron +EPDM	ASTM A536 Grade 65-45-12+ASTM D2000
10	Body	Ductile Iron	ASTM A536 Grade 65-45-12
11	Sealing Ring	EPDM	ASTM D2000
12	Retaining Ring	C95400	ASTM B148
13	Gland	Ductile Iron	ASTM A536 Grade 65-45-12
14	Terminal Pad	Ductile Iron	ASTM A536 Grade 65-45-12
15	Link Block	Ductile Iron	ASTM A536 Grade 65-45-12
16	Nut	Stainless Steel 304 or Steel 1045	ASTM A276 or ASTM A29
17	Studs	Stainless Steel 304 or Steel 1045	ASTM A276 or ASTM A29
18	Washer	Steel 1045	ASTM A29
19	Inner Hexagon Screw	Steel 1045	ASTM A29
20	Master Screw	C95400	ASTM B148
21	Plug	C95400	ASTM B148

Dimensions

Size	DN	L	D	H
2½"	65	190	178	292
3"	80	203	191	322
4"	100	229	229	342
5"	125	254	254	412
6"	150	267	279	448
8"	200	292	343	534
10"	250	330	406	635
12"	300	358	483	720

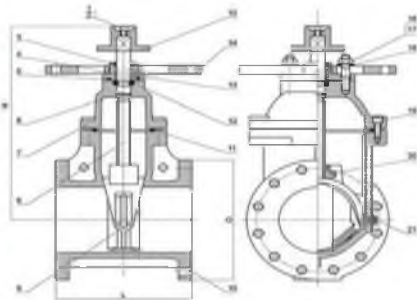

Resilient Wedge NRS Gate valve – Grooved End

Technical Features

- Nominal Pressure: 300PSI
- Groove standard: Metric or ANSI / AWWA C606
- Face to Face Standard: ASME B16.10
- Sizes: 2½", 3", 4", 5", 6", 8", 10", 12"
- Approvals: UL, CUL, FM, NSF / ANSI 61 & NSF / ANSI 372
- Maximum Working Pressure: 300PSI (Maximum Testing Pressure: 600 PSI) conforms to UL262, ULC / ORD C262-92, FM 1120 / 1130
- Maximum Working Temperature: 80°C / 176°F
- Coating Details Epoxy coated interior and exterior by Electrostatic Spray or Coating upon request
- NPT plug on body with 2 operating nuts
- Certified lead-free by NSF / ANSI 61 & NSF / ANSI 372 is available

Valve Material List

NO.	Name	Material	Standard
1	Gasket	Stainless Steel 304 or C95400	ASTM A276 or ASTM B148
2	Bonnet	Ductile Iron	ASTM A536 Grade 65-45-12
3	Packing	Graphite	
4	Disc	Ductile Iron +EPDM	ASTM A536 Grade 65-45-12+ASTM D2000
5	Body	Ductile Iron	ASTM A536 Grade 65-45-12
6	Sealing Ring	EPDM	ASTM D2000
7	Bolt	Stainless Steel 304 or Steel 1045	ASTM A276 or ASTM A29
8	Gland	Ductile Iron	ASTM A536 Grade 65-45-12
9	Nut	Stainless Steel 304 or Steel 1045	ASTM A276 or ASTM A29
10	Flat Washer	Stainless Steel 304 or Steel 1045	ASTM A276 or ASTM A29
11	Bolt	Stainless Steel 304 or Steel 1045	ASTM A276 or ASTM A29
12	Handwheel	Ductile Iron	ASTM A536 Grade 65-45-12
13	Lock Nut	C95400	ASTM B148
14	Locating Screw	Stainless Steel 304 or Steel 1045	ASTM A276 or ASTM A29
15	Stem	Stainless Steel 304 or C95400	ASTM A276 or ASTM B148
16	Stem Nut	C95400	ASTM B148
17	Plug	C95400	ASTM B148
18	Lifting Nut	CF8/CF8M or C95400	ASTM A351 or ASTM B148
19	Pin	Stainless Steel 304	ASTM A276
20	Sealing Ring	EPDM	ASTM D2000



Dimensions

Size	DN	L	F	D	E	G	H
2½"	65	190	15.9	73	68.1		
3"	80	203	15.9	76.1	72.3	7.9	292
4"	100	229	15.9	88.9	84.9	9.5	322
5"	125	254	15.9	130.7	135.5	9.5	412
6"	150	267	15.9	141.3	137		
8"	200	292	19	165.1	160.8	9.5	448
				169.3	163.9		
10"	250	330	19	216.3	211.6	11.1	534
				219.1	214.3		
12"	300	356	19	323.9	318.3	12.7	720

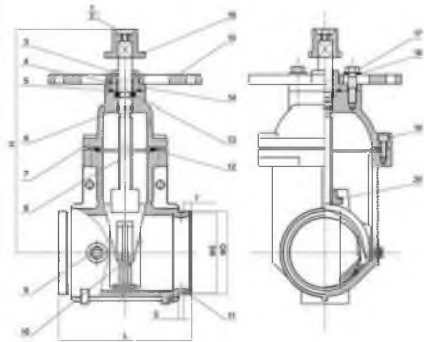

Resilient Wedge NRS Gate valve – Grooved x Flanged End

Technical Features

- Nominal Pressure: 300PSI
- Face to Face Standard: ASME B16.10
- Sizes: 2½", 3", 4", 5", 6", 8", 10", 12"
- Flange Standard: ASME / ANSI B16.1 Class 125 or ASME / ANSI B16.42 Class 150 or BS EN1092-2 PN16 or GB / T9113.1
- Groove Standard: Metric or ANSI / AWWA C806
- Approvals: UL, CUL, FM, NSF / ANSI 61 & NSF / ANSI 372
- Maximum Working Pressure: 300PSI (Maximum Testing Pressure: 600 PSI) conforms to UL262, ULC / ORD C262-92 , FM 1120 / 1130
- Maximum Working Temperature: 80°C / 178°F
- Coating Details: Epoxy coated interior and exterior by Electrostatic Spray or Coating upon request
- NPT plug on body with 2 operating nuts
- Certified lead-free by NSF / ANSI 61 & NSF / ANSI 372 is available

Valve Material List

NO	Name	Material	Standard
1	Flat Washer	Steel 1045 or Stainless Steel 304	ASTM A29 or ASTM A276
2	Hexag Socket Screw	Steel 1045 or Stainless Steel 304	ASTM A29 or ASTM A276
3	Sealing Ring	EPDM	ASTM D2000
4	O-Ring	EPDM	ASTM D2000
5	Sealing Ring	EPDM	ASTM D2000
6	O-Ring	EPDM	ASTM D2000
7	Bonnet	Ductile Iron	ASTM A536 Grade 65-45-12
8	Stem	Stainless Steel 304 or C95400	ASTM A276 or ASTM B148
9	Plug	Stainless Steel 304 or C95400	ASTM A276 or ASTM B148
10	Disc	Ductile Iron +EPDM	ASTM A536 Grade 65-45-12/ASTM D2000
11	Body	Ductile Iron	ASTM A536 Grade 65-45-12
12	Sealing Ring	EPDM	ASTM D2000
13	Retaining Ring	C85400	ASTM B148
14	Gland	Ductile Iron	ASTM A536 Grade 65-45-12
15	Post Flange	Ductile Iron	ASTM A536 Grade 65-45-12
16	Wrench Nut	Ductile Iron	ASTM A536 Grade 65-45-12
17	Bolt	Stainless Steel 304 or Steel 1045	ASTM A276 or ASTM A29
18	Washer	Stainless Steel 304 or Steel 1045	ASTM A276 or ASTM A29
19	Hexag Socket Screw	Steel 1045 or Stainless Steel 304	ASTM A29 or ASTM A276
20	Stem Nut	CF8 or C95400	ASTM A351 or ASTM B148

Dimensions

Size	DN	L	D	F	D2	E	G	H
2½"	65	190	178	15.0	73	69.1	7.9	292
						76.1	72.3	
3"	80	203	191	15.0	88.9	84.9	7.9	322
4"	100	229	229	15.0	114.3	110.1	9.5	342
5"	125	254	254	15.0	139.7	135.5	9.5	412
					141.3	137		
6"	150	267	279	15.0	165.1	160.8	9.5	446
					168.3	163.9		
8"	200	292	343	18	218.3	211.6	11.1	534
					219.1	214.3		
10"	250	330	408	19	273	268.3	12.7	635
12"	300	358	483	18	323.9	318.3	12.7	720

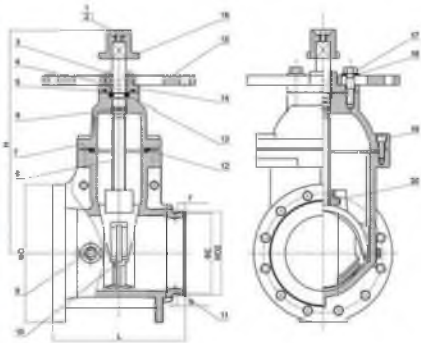

Resilient Wedge OS & Y Gate Valve – Flanged End

Technical Features

- Nominal Pressure: 300PSI
- Conforms: ANSI / AWWA C515 Standard
- Face to Face Standard : ASME B16.10
- Sizes: 2½", 3", 4", 5", 6", 8", 10", 12"
- Flange Standard: ASME / ANSI B16.1 Class 125 or ASME / ANSI B16.42 Class 150 or BS EN1092-2 PN16 or GB / T9113.1
- Approvals: FM, UL, CUL, NSF / ANSI 61 & NSF / ANSI 372
- Maximum Working Pressure: 300PSI (Maximum Testing Pressure: 600 PSI) conforms to UL262, ULC / ORD C262-92 , FM 1120 / 1130
- Maximum Working Temperature: 80°C / 176°F
- Coating Details: Epoxy coated interior and exterior by Electrostatic Spray or Coating upon request
- NPT plug on body with 2 operating nuts
- Certified lead-free by NSF/ANSI 61 & NSF / ANSI 372 is available



Valve Material List

NO.	Name	Material	Standard
1	Gatelet	Stainless Steel 304 or C95400	ASTM A276 or ASTM B148
2	Bonnet	Ductile Iron	ASTM A536 Grade 65-45-12
3	Packing	Graphite	
4	Disc	Ductile Iron +EPDM	ASTM A536 Grade 65-45-12+ASTM D2600
5	Body	Ductile Iron	ASTM A536 Grade 65-45-12
6	Sealing Ring	EPDM	ASTM D2600
7	Bolt	Stainless Steel 304 or Steel 1045	ASTM A276 or ASTM A29
8	Gland	Ductile Iron	ASTM A536 Grade 65-45-12
9	Nut	Stainless Steel 304 or Steel 1045	ASTM A276 or ASTM A29
10	Flat Washer	Stainless Steel 304 or Steel 1045	ASTM A276 or ASTM A29
11	Bolt	Stainless Steel 304 or Steel 1045	ASTM A276 or ASTM A29
12	Handwheel	Ductile Iron	ASTM A536 Grade 65-45-12
13	Lock Nut	C95400	ASTM B148
14	Locating Screw	Stainless Steel 304 or Steel 1045	ASTM A276 or ASTM A29
15	Stem	Stainless Steel 304 or C95400	ASTM A276 or ASTM B148
16	Stem Nut	C95400	ASTM B148
17	Plug	C95400	ASTM B148
18	Lifting Nut	CF8 or C95400	ASTM A351 or ASTM B148
19	Pin	Stainless Steel 304	ASTM A276
20	Sealing Ring	EPDM	ASTM D2600

Dimensions

Size	DN	L	D	H
2½"	65	190	178	370
3"	80	203	191	420
4"	100	229	229	447
5"	125	254	254	547
6"	150	267	279	607
8"	200	292	343	754
10"	250	330	406	890
12"	300	356	463	1031

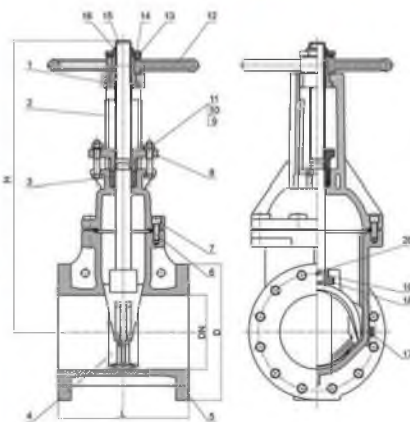

Resilient Wedge OS & Y Gate Valve – Grooved End

Technical Features

- Nominal Pressure: 300PSI
- Conforms: ANSI / AWWA C515 Standard
- Groove Standard: ANSI / AWWA C806 or Metric
- Face to Face Standard: ASME B16.10
- Sizes: 2½", 3", 4", 5", 6", 8", 10", 12"
- Approvals: FM, UL, CUL, NSF / ANSI 61 & NSF / ANSI 372
- Maximum Working Pressure: 300PSI (Maximum Testing Pressure: 600 PSI) conforms to UL262, ULC / ORD C262-92 , FM 1120 / 1130
- Maximum Working Temperature: 80°C / 178°F
- Coating Details: Epoxy coated interior and exterior by Electrostatic Spray or Coating upon request
- NPT plug on body with 2 operating nuts
- Certified lead-free by NSF / ANSI 61 & NSF / ANSI 372 is available

Valve Material List

NO.	Name	Material	Standard
1	Gasket	Stainless Steel 304 or C95400	ASTM A276 or ASTM B148
2	Bonnet	Ductile Iron	ASTM A536 Grade 65-45-12
3	Packing	Graphite	
4	Disc	Ductile Iron +EPDM	ASTM A536 Grade 65-45-12/ASTM D2000
5	Body	Ductile Iron	ASTM A536 Grade 65-45-12
6	Sealing Ring	EPDM	ASTM D2000
7	Bolt	Stainless Steel 304 or Steel 1045	ASTM A276 or ASTM A29
8	Gland	Ductile Iron	ASTM A536 Grade 65-45-12
9	Nut	Stainless Steel 304 or Steel 1045	ASTM A276 or ASTM A29
10	Flat Washer	Stainless Steel 304 or Steel 1045	ASTM A276 or ASTM A29
11	Bolt	Stainless Steel 304 or Steel 1045	ASTM A276 or ASTM A29
12	Handwheel	Ductile Iron	ASTM A536 Grade 65-45-12
13	Lock Nut	C95400	ASTM B148
14	Locating Screw	Stainless Steel 304 or Steel 1045	ASTM A276 or ASTM A29
15	Stem	Stainless Steel 304 or C95400	ASTM A276 or ASTM B148
16	Stem Nut	C95400	ASTM B148
17	Plug	C95400	ASTM B148
18	Lifting Nut	CF8 or C95400	ASTM A351 or ASTM B148
19	Pin	Stainless Steel 304	ASTM A276
20	Sealing Ring	EPDM	ASTM D2000

Dimensions

Size	DN	L	F	D	E	G	H
2½"	85	190	15.9	73	69.1	7.9	370
				76.1	72.3		
3"	90	203	15.9	88.9	84.9	7.9	420
				91.4	87.4		
4"	100	229	15.9	114.3	110.1	9.5	447
				117.8	113.6		
5"	125	264	15.9	139.7	135.5	9.5	547
				142.2	138.0		
6"	150	267	15.9	165.1	160.8	9.5	607
				167.6	163.3		
8"	200	292	19	216.3	211.6	11.1	754
				218.8	214.1		
10"	250	330	19	273	268.3	12.7	890
				275.5	270.8		
12"	300	356	19	323.9	318.3	12.7	1031
				326.4	320.8		

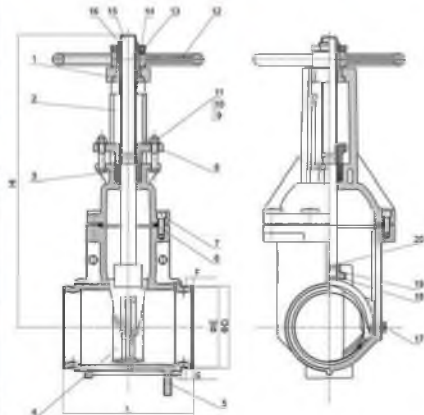

Resilient Wedge OS & Y Gate Valve – Flanged x Grooved End

Technical Features

- Nominal Pressure: 300PSI
- Conforms: ANSI / AWWA C515 Standard
- Face to Face Standard : ASME B16.10
- Sizes: 2½", 3", 4", 5", 6", 8", 10", 12"
- Flange Standard: ASME / ANSI B16.1 Class 125 or ASME / ANSI B16.42 Class 150 or BS EN1092-2 PN16 or GB / T9113.1
- Groove Standard: ANSI / AWWA C806 or Metric
- Approvals: FM, UL, CUL, NSF / ANSI 61 & NSF/ANSI 372
- Maximum Working Pressure: 300PSI (Maximum Testing Pressure: 600 PSI) conforms to UL262, ULC / ORD C262-92 , FM 1120 / 1130
- Maximum Working Temperature: 80°C / 176°F
- Coating Details: Epoxy coated interior and exterior by Electrostatic Spray or Coating upon request
- NPT plug on body with 2 operating nuts
- Certified lead-free by NSF / ANSI 61 & NSF / ANSI 372 is available

Valve Material List

NO.	Name	Material	Standard
1	Gasket	Stainless Steel 304 or C85400	ASTM A276 or ASTM B148
2	Bonnet	Ductile Iron	ASTM A536 Grade 65-45-12
3	Packing	Graphite	
4	Disc	Ductile Iron + EPDM	ASTM A536 Grade 65-45-12/ASTM D2000
5	Body	Ductile Iron	ASTM A536 Grade 65-45-12
6	Sealing Ring	EPDM	ASTM D2000
7	Bolt	Stainless Steel 304 or Steel 1045	ASTM A276 or ASTM A29
8	Gland	Ductile Iron	ASTM A536 Grade 65-45-12
9	Nut	Stainless Steel 304 or Steel 1045	ASTM A276 or ASTM A29
10	Flat Washer	Stainless Steel 304 or Steel 1045	ASTM A276 or ASTM A29
11	Bolt	Stainless Steel 304 or Steel 1045	ASTM A276 or ASTM A29
12	Handwheel	Ductile Iron	ASTM A536 Grade 65-45-12
13	Lock Nut	C85400	ASTM B148
14	Locating Screw	Stainless Steel 304 or Steel 1045	ASTM A276 or ASTM A29
15	Stem	Stainless Steel 304 or C85400	ASTM A276 or ASTM B148
16	Stem Nut	C85400	ASTM B148
17	Plug	C85400	ASTM B148
18	Lifting Nut	CF8 or C85400	ASTM A351 or ASTM B148
19	Pin	Stainless Steel 304	ASTM A276
20	Sealing Ring	EPDM	ASTM D2000

Dimensions

Size	DNv	L	D	F	DC	E	G	H
2½"	65	190	178	15.9	73	69.1	7.9	370
3"	80	203	191	15.9	88.9	84.9	7.9	420
4"	100	229	229	15.9	114.3	110.1	9.5	447
5"	125	254	254	15.9	139.7	135.5	9.5	547
					141.3	137		
6"	150	287	279	15.9	165.1	160.8	9.5	607
					168.3	163.9		
8"	200	292	343	19	216.3	211.6		754
					219.1	214.3	11.1	
10"	250	330	406	19	273	268.3	12.7	890
12"	300	356	463	19	323.9	318.3	12.7	1031

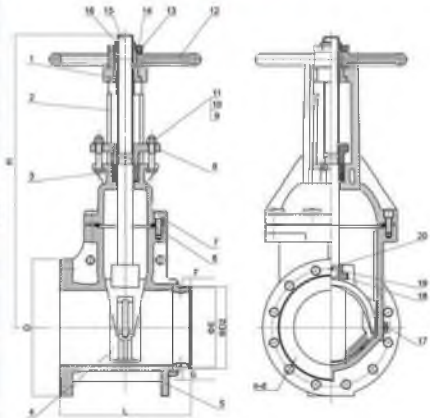

Resilient Wedge NRS Gate Valve – Flanged End

Technical Features

- Nominal Pressure: 300PSI
- Conforms: ANSI / AWWA C515 Standard
- Face to Face Standard : ASME B16.10
- Sizes: 2", 2½", 3", 4", 5", 6", 8", 10", 12"
- 2" FM only
- Flange Standard: ASME / ANSI B16.1 Class 125 or ASME / ANSI B16.42 Class 150 or BS EN1092-2 PN16 or GB / T9113.1
- Approvals: FM, UL, CUL, NSF / ANSI 61 & NSF / ANSI 372
- Maximum Working Pressure: 300PSI (Maximum Testing Pressure: 600 PSI) conforms to UL262, ULC / ORD C262-92 , FM 1120 / 1130
- Maximum Working Temperature: 80°C / 176°F
- Coating Details: Epoxy coated interior and exterior by Electrostatic Spray or Coating upon request
- NPT plug on body with 2 operating nuts
- Certified lead-free by NSF / ANSI 61 & NSF / ANSI 372 is available
- With and Without Post Flange are available

Valve Material List

NO	Name	Material	Standard
1	Flat Washer	Steel 1045 or Stainless Steel 304	ASTM A29 or ASTM A276
2	Hexagon Socket Screw	Steel 1045 or Stainless Steel 304	ASTM A29 or ASTM A276
3	Sealing Ring	EPDM	ASTM D2000
4	O-ring	EPDM	ASTM D2000
5	Sealing Ring	EPDM	ASTM D2000
6	O-ring	EPDM	ASTM D2000
7	Bonnet	Ductile Iron	ASTM A536 Grade 65-45-12
8	Stem	Stainless Steel 304 or Steel 1045	ASTM A276 or ASTM A29
9	Plug	Stainless Steel 304 or Steel 1045	ASTM A276 or ASTM A29
10	Disc	Ductile Iron +EPDM	ASTM A536 Grade 65-45-12/ASTM D2000
11	Body	Ductile Iron	ASTM A536 Grade 65-45-12
12	Sealing Ring	EPDM	ASTM D2000
13	Retaining Ring	C98400	ASTM B148
14	Gland	Ductile Iron	ASTM A536 Grade 65-45-12
15	Post Flange	Ductile Iron	ASTM A536 Grade 65-45-12
16	Wrench Nut	Ductile Iron	ASTM A536 Grade 65-45-12
17	Bolt	Stainless Steel 304 or Steel 1045	ASTM A276 or ASTM A29
18	Washer	Stainless Steel 304 or Steel 1045	ASTM A276 or ASTM A29
19	Hexagon Socket Screw	Steel 1045 or Stainless Steel 304	ASTM A29 or ASTM A276
20	Stem Nut	CF8 or C95400	ASTM A351 or ASTM B148

Dimensions

Size	DN	L	D	H
2"	50	178	152	285
2½"	65	190	178	292
3"	80	203	191	322
4"	100	229	229	342
5"	125	254	254	412
6"	150	267	279	448
8"	200	292	343	534
10"	250	330	408	635
12"	300	356	483	720

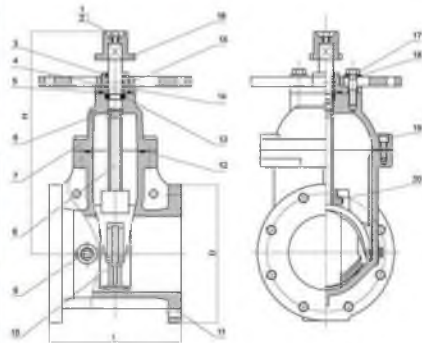

Resilient Wedge NRS Gate Valve – Grooved End

Technical Features

- Nominal Pressure: 300PSI
- Conforms to: ANSI / AWWA C515 Standard
- Groove Standard: ANSI / AWWA C606 or Metric
- Face to Face Standard: ASME B16.10
- Sizes: 2½", 3", 4", 5", 6", 8", 10", 12"
- Approvals: FM, UL, CUL, NSF / ANSI 61 & NSF / ANSI 372
- Maximum Working Pressure: 300PSI (Maximum Testing Pressure: 600 PSI) conforms to UL262, ULG/ORD C262-92 , FM 1120 / 1130
- Maximum Working Temperature: 80°C / 176°F
- Coating Details: Epoxy coated interior and exterior by Electrostatic Spray or Coating upon request
- NPT plug on body with 2 operating nuts
- Certified lead-free by NSF / ANSI 61 & NSF / ANSI 372 is available
- With and Without Post Flange are available



Valve Material List

NO.	Name	Material	Standard
1	Flat Washer	Steel 1045 or Stainless Steel 304	ASTM A29 or ASTM A276
2	Hexagon Socket Screw	Steel 1045 or Stainless Steel 304	ASTM A29 or ASTM A276
3	Sealing Ring	EPDM	ASTM D2000
4	O-ring	EPDM	ASTM D2000
5	Sealing Ring	EPDM	ASTM D2000
6	O-ring	EPDM	ASTM D2000
7	Bonnet	Ductile Iron	ASTM A536 Grade 65-45-12
8	Stem	Stainless Steel 304 or Steel 1045	ASTM A276 or ASTM A29
9	Plug	Stainless Steel 304 or Steel 1045	ASTM A276 or ASTM A29
10	Disc	Ductile Iron +EPDM	ASTM A536 Grade 65-45-12-ASTM D2000
11	Body	Ductile Iron	ASTM A536 Grade 65-45-12
12	Sealing Ring	EPDM	ASTM D2000
13	Retaining Ring	C95400	ASTM B148
14	Gland	Ductile Iron	ASTM A536 Grade 65-45-12
15	Post Flange	Ductile Iron	ASTM A536 Grade 65-45-12
16	Wrench Nut	Ductile Iron	ASTM A536 Grade 65-45-12
17	Bolt	Stainless Steel 304 or Steel 1045	ASTM A276 or ASTM A29
18	Washer	Stainless Steel 304 or Steel 1045	ASTM A276 or ASTM A29
19	Hexagon Socket Screw	Steel 1045 or Stainless Steel 304	ASTM A29 or ASTM A276
20	Stem Nut	CF8 or C95400	ASTM A351 or ASTM B148

Dimensions

Size	DN	L	F	D	E	G	H
2½"	65	190	15.9	73	69.1	7.9	292
3"	80	203	15.9	78.1	72.3	7.9	322
4"	100	229	15.9	114.3	110.1	9.5	342
5"	125	254	15.9	139.7	135.5	9.5	412
6"	150	267	15.9	141.3	137	9.5	448
8"	200	282	19	216.3	211.6	11.1	534
10"	250	330	19	219.1	214.3	12.7	635
12"	300	356	19	323.9	318.3	12.7	720

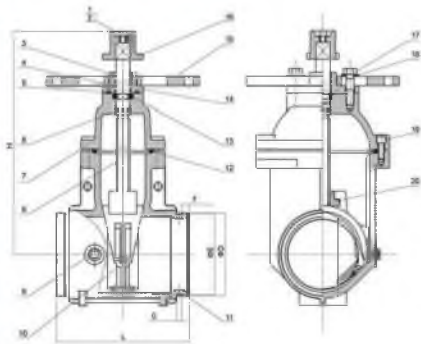

Resilient Wedge NRS Gate Valve – Flanged x Grooved End

Technical Features

- Nominal Pressure: 300PSI
- Conforms: ANSI / AWWA C515 Standard
- Flange Standard: ASME / ANSI B16.1 Class 125 or ASME / ANSI B16.42 Class 150 or BS EN1092-2 PN16 or GB / TB113.1
- Groove Standard: ANSI / AWWA C606 or Metric
- Face to Face Standard: ASME B16.10
- Sizes: 2½", 3", 4", 5", 6", 8", 10", 12"
- Approvals: FM, UL, CUL, NSF / ANSI 61 & NSF/ANSI 372
- Maximum Working Pressure: 300PSI (Maximum Testing Pressure: 600 PSI) conforms to UL262, ULC / ORD C262-92, FM 1120 / 1130
- Maximum Working Temperature: 80°C / 176°F
- Coating Details: Epoxy coated interior and exterior by Electrostatic Spray or Coating upon request
- NPT plug on body with 2 operating nuts
- Certified lead-free by NSF / ANSI 61 & NSF / ANSI 372 is available
- With and Without Post Flange are available

Valve Material List

NO.	Name	Material	Standard
1	Flat Washer	Steel 1045 or Stainless Steel 304	ASTM A29 or ASTM A276
2	Hexagon Socket Screw	Steel 1045 or Stainless Steel 304	ASTM A29 or ASTM A276
3	Sealing Ring	EPDM	ASTM D2000
4	O-Ring	EPDM	ASTM D2000
5	Sealing Ring	EPDM	ASTM D2000
6	O-Ring	EPDM	ASTM D2000
7	Bonnet	Ductile Iron	ASTM A536 Grade 65-45-12
8	Stem	Stainless Steel 304 or Steel 1045	ASTM A276 or ASTM A29
9	Plug	Stainless Steel 304 or Steel 1045	ASTM A276 or ASTM A29
10	Disc	Ductile Iron + EPDM	ASTM A536 Grade 65-45-12/ASTM D2000
11	Body	Ductile Iron	ASTM A536 Grade 65-45-12
12	Sealing Ring	EPDM	ASTM D2000
13	Retaining Ring	C95400	ASTM B148
14	Gland	Ductile Iron	ASTM A536 Grade 65-45-12
15	Post Flange	Ductile Iron	ASTM A536 Grade 65-45-12
16	Wrench Nut	Ductile Iron	ASTM A536 Grade 65-45-12
17	Bolt	Stainless Steel 304 or Steel 1045	ASTM A276 or ASTM A29
18	Washer	Stainless Steel 304 or Steel 1045	ASTM A276 or ASTM A29
19	Hexagon Socket Screw	Steel 1045 or Stainless Steel 304	ASTM A29 or ASTM A276
20	Stem Nut	CFS or C95400	ASTM A351 or ASTM B148

Dimensions

Size	DN	L	D	F	D2	E	G	H
2½"	65	190	178	15.9	73	69.1	7.9	292
3"	80	203	191	15.9	85.9	84.9	7.9	322
4"	100	229	229	15.9	114.3	110.1	9.5	342
5"	125	254	254	15.9	139.7	135.5	9.5	412
					141.3	137		
6"	150	267	279	15.9	165.1	160.8	9.5	448
					168.3	163.9		
8"	200	292	343	19	216.3	211.6	11.1	534
					219.1	214.3		
10"	250	330	406	19	273	268.3	12.7	635
12"	300	356	483	19	323.9	318.3	12.7	720

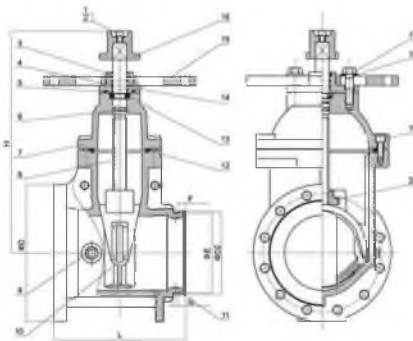

Resilient Wedge NRS Gate Valve – Flanged x Mechanical Joint End

Technical Features

- Nominal Pressure: 300PSI
- Conforms: ANSI / AWWA C515 Standard
- Sizes: 2", 3", 4", 6", 8", 10", 12"
- 2" FM only
- Flange Standard: ASME / ANSI B16.1 Class 125 or ASME / ANSI B16.42 Class 150 or BS EN1092-2 PN16 or GB / T9113.1
- Mechanical Standard : ANSI / AWWA 110 or ANSI / AWWA C153
- Approvals: FM, UL, CUL, NSF / ANSI 61 & NSF / ANSI 372
- Maximum Working Pressure: 300PSI (Maximum Testing Pressure: 600 PSI) conforms to UL262, ULC / ORD C262-92 , FM 1120 / 1130
- Maximum Working Temperature: 80°C / 176°F
- Coating Details: Epoxy coated interior and exterior by Electrostatic Spray or Coating upon request
- NPT plug on body with 1 operating nut
- Certified lead-free by NSF/ANSI 61 & NSF / ANSI 372 is available.
- With and Without Post Flange are available



Valve Material List

NO.	Name	Material	Standard
1	Flat Washer	Steel 1045 or Stainless Steel 304	ASTM A29 or ASTM A276
2	Hexage Socket Size	Steel 1045 or Stainless Steel 304	ASTM A29 or ASTM A276
3	Sealing Ring	EPDM	ASTM D2000
4	O-Ring	EPDM	ASTM D2000
5	Sealing Ring	EPDM	ASTM D2000
6	O-Ring	EPDM	ASTM D2000
7	Bornet	Ductile Iron	ASTM A536 Grade 65-45-12
8	Stem	Stainless Steel 304 or Steel 1045	ASTM A276 or ASTM A29
9	Plug	Stainless Steel 304 or Steel 1045	ASTM A276 or ASTM A29
10	Disc	Ductile Iron + EPDM	ASTM A536 Grade 65-45-12/ASTM D2000
11	Body	Ductile Iron	ASTM A536 Grade 65-45-12
12	Sealing Ring	EPDM	ASTM D2000
13	Retaining Ring	C95400	ASTM B148
14	Gland	Ductile Iron	ASTM A536 Grade 65-45-12
15	Post Flange	Ductile Iron	ASTM A536 Grade 65-45-12
16	Wrench Nut	Ductile Iron	ASTM A536 Grade 65-45-12
17	Bolt	Stainless Steel 304 or Steel 1045	ASTM A276 or ASTM A29
18	Washer	Stainless Steel 304 or Steel 1045	ASTM A276 or ASTM A29
19	Hexage Socket Size	Steel 1045 or Stainless Steel 304	ASTM A29 or ASTM A276
20	Stem Nut	C/F8 or C95400	ASTM A351 or ASTM B 148

Dimensions

Size	DN	L	D	D1	H
2"	50	178	152	152	265
3"	80	203	191	195	322
4"	100	228	229	232	342
6"	150	267	279	282	448
8"	200	292	343	340	534
10"	250	330	406	399	635
12"	300	356	483	456	720

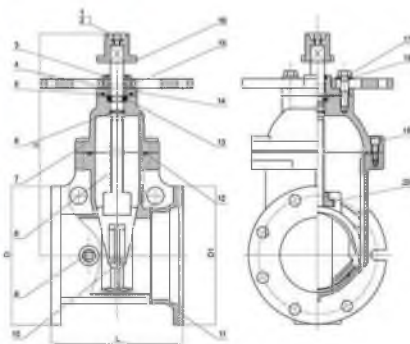

Resilient Wedge NRS Gate Valve – Mechanical Joint x Mechanical Joint End

Technical Features

- Nominal Pressure: 300PSI
- Conforms: ANSI / AWWA C515 Standard
- Sizes: 2", 3", 4", 6", 8", 10", 12"
- 2" FM only
- Mechanical Standard : ANSI / AWWA 110 or ANSI / AWWA C153
- Approvals: FM, UL, CUL, NSF / ANSI 61 & NSF / ANSI 372
- Maximum Working Pressure: 300PSI (Maximum Testing Pressure: 600 PSI) conforms to UL262, UL/ORD C262-92 , FM 1120 / 1130
- Maximum Working Temperature: 80°C / 176°F
- Coating Details Epoxy coated interior and exterior by Electrostatic Spray or Coating upon request
- Certified lead-free by NSF / ANSI 61 & NSF / ANSI 372 is available
- With and Without Post Flange are available



Valve Material List

NO.	Name	Material	Standard
1	Flat Washer	Steel 1045 or Stainless Steel 304	ASTM A29 or ASTM A276
2	Hexagon Socket Screw	Steel 1045 or Stainless Steel 304	ASTM A29 or ASTM A276
3	Sealing Ring	EPDM	ASTM D2000
4	O-Ring	EPDM	ASTM D2000
5	Sealing Ring	EPDM	ASTM D2000
6	O-Ring	EPDM	ASTM D2000
7	Bonnet	Ductile Iron	ASTM A536 Grade 65-45-12
8	Stem	Stainless Steel 304 or Steel 1045	ASTM A276 or ASTM A29
9	Plug	Stainless Steel 304 or Steel 1045	ASTM A276 or ASTM A29
10	Disc	Ductile Iron +EPDM	ASTM A536 Grade 65-45-12+ASTM D2000
11	Body	Ductile Iron	ASTM A536 Grade 65-45-12
12	Sealing Ring	EPDM	ASTM D2000
13	Retaining Ring	C95400	ASTM B148
14	Gland	Ductile Iron	ASTM A536 Grade 65-45-12
15	Post Flange	Ductile Iron	ASTM A536 Grade 65-45-12
16	Wrench Nut	Ductile Iron	ASTM A536 Grade 65-45-12
17	Ball	Stainless Steel 304 or Steel 1045	ASTM A276 or ASTM A29
18	Washer	Stainless Steel 304 or Steel 1045	ASTM A276 or ASTM A29
19	Hexagon Socket Screw	Steel 1045 or Stainless Steel 304	ASTM A29 or ASTM A276
20	Stem Nut	C/F8 or C95400	ASTM A351 or ASTM B148

Dimensions

Size	DN	L	D	H
2"	50	178	152	265
3"	80	203	195	322
4"	100	229	232	342
6"	150	267	282	446
8"	200	292	340	534
10"	250	330	399	635
12"	300	358	456	720

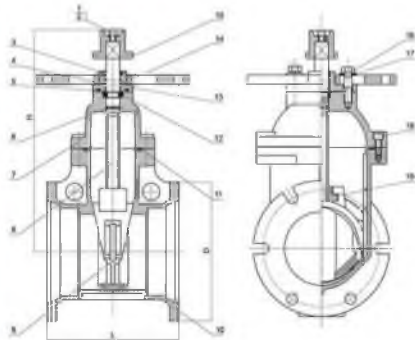

Resilient Wedge OS&Y Gate Valve – Flanged End

Technical Features

- Nominal Pressure: 200PSI
- Flange Standard: ASME / ANSI B16.1 Class 125 or ASME / ANSI B16.42 Class 150 or BS EN1092-2 PN16 or GB / T9113.1
- Face to Face Standard: ASME B16.10
- Sizes: 2", 2½", 3", 4", 5", 6", 8", 10", 12" with FM UL CUL
- 14", 16" with FM only
- Approvals: FM, UL, CUL, NSF / ANSI 61 & NSF / ANSI 372
- Maximum Working Pressure: 200PSI (Maximum Testing Pressure: 400 PSI) conforms to UL 262, ULC / ORD C262-92, FM 1120 / 1130
- Maximum Working Temperature: 80°C / 176°F
- Coating Details: Epoxy coated interior and exterior by Electrostatic Spray or Coating upon request
- NPT plug on body with 2 operating nuts
- Certified lead-free by NSF / ANSI 61 & NSF / ANSI 372 is available



Valve Material List

NO	Name	Material	Standard
1	Body	Ductile Iron	ASTM A536 65-45-12
2	Disc	Ductile Iron +EPDM	ASTM A536 65-45-12 +ASTM D2000
3	Connecting Part	C95400	ASTM B148
4	Sealing Pad	EPDM	ASTM D2000
5	Stem	Stainless Steel 304	ASTM A276
6	Yoke	Ductile Iron	ASTM A536 65-45-12
7	Bolt	Steel 1045	ASTM A29
8	Gland	Ductile Iron	ASTM A536 65-45-12
9	Nut	Steel 1045	ASTM A29
10	Rotating Nut	C95400	ASTM B148
11	Handwheel	Steel 1045	ASTM A29
12	Lock Nut	Steel 1045	ASTM A29
13	Countersunk Head Bolt	Steel 1045	ASTM A29
14	Cylinder Pin	Stainless Steel 304	ASTM A276

Dimensions

Size	L	H	øD
2"	178	313	152
2½"	190	340	178
3"	203	387	181
4"	229	440	229
5"	254	546	254
6"	267	607	279
8"	292	786	343
10"	330	946	406
12"	356	1110	483

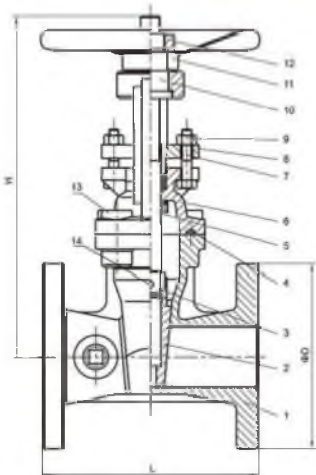

Resilient Wedge OS&Y Gate Valve – Flanged x Grooved End

Technical Features

- Nominal Pressure: 200PSI
- Flange Standard: ASME / ANSI B16.1 Class 125 or ASME / ANSI B16.42 Class 150 or BS EN1092-2 PN16 or GB / T9113 1
- Groove standard : ANSI / AWWA C806 or Metric
- Face to Face Standard: ASME B16.10
- Sizes: 2", 2¼", 3", 4", 5", 6", 8", 10", 12"
- Approvals: FM, UL, CUL, NSF / ANSI 61 & NSF / ANSI 372
- Maximum Working Pressure: 200 PSI (Maximum Testing Pressure: 400 PSI) conforms to UL 262, ULC / ORD C262-92 , FM 1120 / 1130
- Maximum Working Temperature: 80°C / 176°F
- Coating Details: Epoxy coated interior and exterior by Electrostatic Spray or Coating upon request
- NPT plug on body with 2 operating nuts
- Certified lead-free by NSF / ANSI 61 & NSF / ANSI 372 is available



Valve Material List

NO	Name	Material	Standard
1	Body	Ductile Iron	ASTM A536 65-45-12
2	Disc	Ductile Iron +EPDM	ASTM A536 65-45-12 *ASTM D2000
3	Connecting Part	C95400	ASTM B148
4	Sealing Pad	EPDM	ASTM D2000
5	Stem	Stainless Steel 304	ASTM A276
6	Yoke	Ductile Iron	ASTM A536 65-45-12
7	Bolt	Steel 1045	ASTM A29
8	Gland	Ductile Iron	ASTM A536 65-45-12
9	Nut	Steel 1045	ASTM A29
10	Rotating Nut	C95400	ASTM B148
11	Handwheel	Steel 1045	ASTM A29
12	Lock Nut	Steel 1045	ASTM A29
13	Countersunk Head Bolt	Steel 1045	ASTM A29
14	Cylinder Pin	Stainless Steel 304	ASTM A276

Dimensions

Size	L	H	eD	eD1	eE	F	G
2"	178	313	152	60.3	57.2	15.9	7.9
2¼"	190	340	178	76.1	72.3	15.9	7.9
3"	203	387	191	88.9	84.9	15.9	7.9
4"	228	440	229	114.3	110.1	15.9	9.5
5"	254	548	254	141.3	137	15.9	9.5
6"	267	607	279	168.3	163.9	15.9	9.5
8"	292	788	343	219.1	214.4	19	11.1
10"	330	946	406	273	268.3	19	12.7
12"	356	1110	483	323.9	318.3	19	12.7

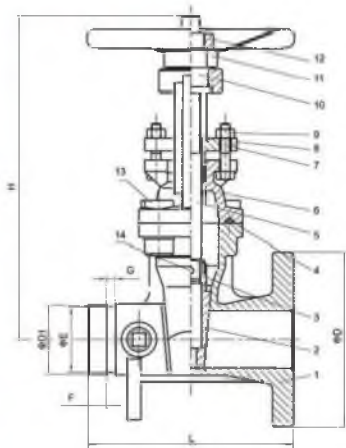

Resilient Wedge OS&Y Gate Valve – Grooved End

Technical Features

- Nominal Pressure: 200PSI
- Groove Standard : ANSI / AWWA C606 or Metric
- Face to Face Standard: ASME B16 10
- Sizes: 2", 2½", 3", 4", 5", 6", 8", 10", 12"
- Approvals: FM,UL, CUL, NSF / ANSI 61 & NSF / ANSI 372
- Maximum Working Pressure: 200PSI (Maximum Testing Pressure: 400 PSI) conforms to UL 262, ULC / ORD C262-92 , FM 1120 / 1130
- Maximum Working Temperature: 80°C / 176°F
- Coating Details: Epoxy coated interior and exterior by Electrostatic Spray or Coating upon request
- NPT plug on body with 2 operating nuts
- Certified lead-free by NSF / ANSI 61 & NSF / ANSI 372 Is available



Valve Material List

NO	Name	Material	Standard
1	Body	Ductile Iron	ASTM A536 65-45-12
2	Disc	Ductile Iron +EPDM	ASTM A536 65-45-12 +ASTM D2000
3	Connecting Part	C95400	ASTM B149
4	Sealing Pad	EPDM	ASTM D2000
5	Stem	Stainless Steel 304	ASTM A276
6	Yoke	Ductile Iron	ASTM A536 65-45-12
7	Bolt	Steel 1045	ASTM A29
8	Gland	Ductile Iron	ASTM A536 65-45-12
9	Nut	Steel 1045	ASTM A29
10	Rotating Nut	C95400	ASTM B148
11	Handwheel	Steel 1045	ASTM A29
12	Lock Nut	Steel 1045	ASTM A29
13	Countersunk Head Bolt	Steel 1045	ASTM A29
14	Cylinder Pin	Stainless Steel 304	ASTM A276

Dimensions

Size	L	H	øD	øE	F	G
2"	179	313	60.3	57.2	15.9	7.9
2½"	190	340	76.1	72.3	15.9	7.9
3"	203	397	88.9	84.9	15.9	7.9
4"	229	440	114.3	110.1	15.9	9.5
5"	254	546	141.3	137	15.9	9.5
6"	267	607	168.3	163.9	15.9	9.5
8"	292	786	219.1	214.4	19	11.1
10"	330	948	273	268.3	19	12.7
12"	356	1110	323.9	318.3	19	12.7

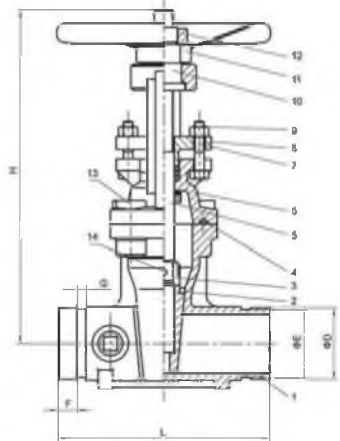

Resilient Wedge NRS Gate Valve – Flanged End

Technical Features

- Nominal Pressure: 200PSI
- Flange Standard: ASME / ANSI B16.1 Class 125 or ASME / ANSI B16.42 Class 150 or BS EN1092-2 PN16 or GB / T9113.1
- Face to Face Standard: ASME B16.10
- Sizes: 2", 2½", 3", 4", 5", 6", 8", 10", 12"
- Approvals: FM, UL, CUL, NSF / ANSI 61 & NSF / ANSI 372
- 2" without UL , CUL
- Maximum Working Pressure: 200PSI (Maximum Testing Pressure: 400 PSI) conforms to UL 262, ULC / ORD C262-92 , FM 1120 / 1130
- Maximum Working Temperature: 80°C / 176°F
- Coating Details: Epoxy coated interior and exterior by Electrostatic Spray or Coating upon request
- NPT plug on body with 2 operating nuts
- Certified lead-free by NSF / ANSI 61 & NSF / ANSI 372 is available



Valve Material List

NO.	Name	Material	Standard
1	Body	Ductile Iron	ASTM A536 65-45-12
2	Disc	Ductile Iron+EPDM	ASTM A536 65-45-12+ASTM D2000
3	Nut	C95400	ASTM B148
4	Gasket	EPDM	ASTM D2000
5	Stem	Stainless Steel 304	ASTM A276
6	Cap	Ductile Iron	ASTM A536 65-45-12
7	Retainer Ring	C95400	ASTM B148
8	O-ring	EPDM	ASTM D2000
9	Wrench Nut	Ductile Iron	ASTM A536 65-45-12
10	Minipad	Steel 1045	ASTM A29
11	Bolt	Steel 1045	ASTM A29
12	Stud	Steel 1045	ASTM A29
13	Nut	Steel 1045	ASTM A29
14	Flat Washer	Steel 1045	ASTM A29
15	Coupling Flange	Ductile Iron	ASTM A536 65-45-12
16	Platen	Ductile Iron	ASTM A536 65-45-12
17	Countersunk Head Bolt	Steel 1045	ASTM A29

Dimensions

Size	L	H	øD
2"	178	265	152
2½"	190	289	178
3"	203	326	190
4"	229	355	229
5"	254	410	254
6"	287	455	279
8"	292	558	343
10"	330	648	406
12"	356	745	483

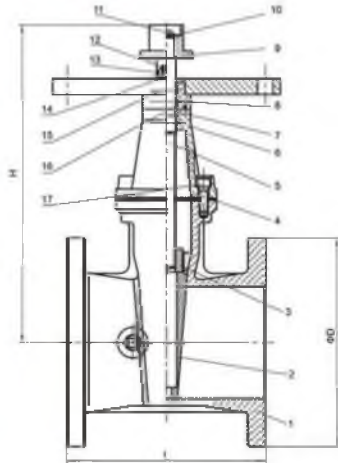

Resilient Wedge NRS Gate Valve – Flanged x Grooved End

Technical Features

- Nominal Pressure: 200PSI
- Flange Standard: ASME / ANSI B16.1 Class 125 or ASME / ANSI B16.42 Class 150 or BS EN1092-2 PN16 or GB / T9113.1
- Groove standard: ANSI / AWWA C606 or Metric
- Face to Face Standard: ASME B16.10.
- Sizes: 2", 2½", 3", 4", 5", 6", 8", 10", 12"
- Approvals: FM, UL, CUL, NSF / ANSI 61 & NSF / ANSI 372
- 2" without UL , CUL
- Maximum Working Pressure: 200PSI (Maximum Testing Pressure: 400 PSI) conforms to UL 282, ULC / ORD C262-92 , FM 1120 / 1130
- Maximum Working Temperature: 80°C / 176°F
- Coating Details: Epoxy coated interior and exterior by Electrostatic Spray or Coating upon request
- NPT plug on body with 2 operating nuts
- Certified lead-free by NSF / ANSI 61 & NSF / ANSI 372 is available



Valve Material List

NO	Name	Material	Standard
1	Body	Ductile Iron	ASTM A536 65-45-12
2	Disc	Ductile Iron+EPDM	ASTM A536 65-45-12 +ASTM D2000
3	Nut	C95400	ASTM B148
4	Gasket	EPDM	ASTM D2000
5	Stem	Stainless Steel 304	ASTM A276
6	Cap	Ductile Iron	ASTM A536 65-45-12
7	Retainer Ring	C95400	ASTM B148
8	O-ring	EPDM	ASTM D2000
9	Wrench Nut	Ductile Iron	ASTM A536 65-45-12
10	Mixpad	Steel 1045	ASTM A29
11	Bolt	Steel 1045	ASTM A29
12	Stud	Steel 1045	ASTM A29
13	Nut	Steel 1045	ASTM A29
14	Flat Washer	Steel 1045	ASTM A29
15	Coupling Flange	Ductile Iron	ASTM A536 65-45-12
16	Flaten	Ductile Iron	ASTM A536 65-45-12
17	Countersunk Head Bolt	Steel 1045	ASTM A29

Dimensions

Size	L	H	øD	øD1	øE	F	G
2"	178	265	152	80.3	57.15	15.9	7.9
2½"	190	289	178	76.1	72.3	15.9	7.9
3"	203	326	191	88.9	84.9	15.9	7.9
4"	229	355	229	114.3	110.1	15.9	9.5
5"	254	410	254	141.3	137	15.9	9.5
6"	267	455	279	168.3	163.9	15.9	9.5
8"	292	558	343	219.1	214.4	19	11.1
10"	330	648	406	273	268.3	19	12.7
12"	356	745	483	323.9	318.3	19	12.7

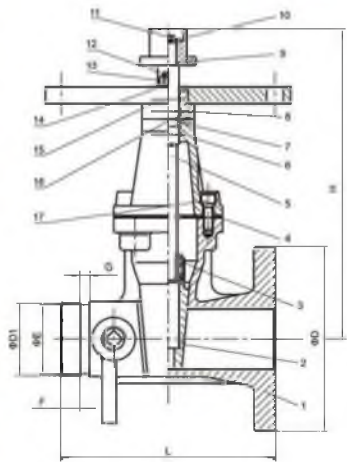

Resilient Wedge NRS Gate Valve – Grooved End

Technical Features

- Nominal Pressure: 200PSI
- Groove standard : ANSI / AWWA C806 or Metric
- Face to Face Standard: ASME B18.10
- Sizes: 2", 2½", 3", 4", 5", 6", 8", 10", 12"
- Approvals: FM, UL, CUL, NSF / ANSI 61 & NSF / ANSI 372
- 2" without UL , CUL
- Maximum Working Pressure, 200PSI (Maximum Testing Pressure: 400 PSI) conforms to UL 262, ULC / ORD C262-92 , FM 1120 / 1130
- Maximum Working Temperature: 80°C / 176°F
- Coating Details: Epoxy coated interior and exterior by Electrostatic Spray or Coating upon request
- NPT plug on body with 2 operating nuts
- Certified lead-free by NSF / ANSI 61 & NSF / ANSI 372 is available



Valve Material List

NO	Name	Material	Standard
1	Body	Ductile Iron	ASTM A536 65-45-12
2	Disc	Ductile Iron+EPDM	ASTM A536 65-45-12+ASTM D2000
3	Nut	C65400	ASTM B148
4	Gasket	EPDM	ASTM D2000
5	Stem	Stainless Steel 304	ASTM A276
6	Cap	Ductile Iron	ASTM A536 65-45-12
7	Retainer Ring	C95400	ASTM B148
8	O-ring	EPDM	ASTM D2000
9	Wrench Nut	Ductile Iron	ASTM A536 65-45-12
10	Minipad	Steel 1045	ASTM A29
11	Bolt	Steel 1045	ASTM A29
12	Stud	Steel 1045	ASTM A29
13	Nut	Steel 1045	ASTM A29
14	Flat Washer	Steel 1045	ASTM A29
15	Coupling Flange	Ductile Iron	ASTM A536 65-45-12
16	Platen	Ductile Iron	ASTM A536 65-45-12
17	Countersunk Head Bolt	Steel 1045	ASTM A29

Dimensions

Size	L	H	øD	øE	F	G
2"	178	265	60.3	57.15	15.9	7.9
2½"	190	289	76.1	72.3	15.9	7.9
3"	203	326	88.9	84.9	15.9	7.9
4"	229	355	114.3	110.1	15.9	9.5
5"	254	410	141.3	137	15.9	9.5
6"	267	455	168.3	163.9	15.9	9.5
8"	292	558	219.1	214.4	19	11.1
10"	330	648	273	268.3	19	12.7
12"	356	745	323.9	318.3	19	12.7

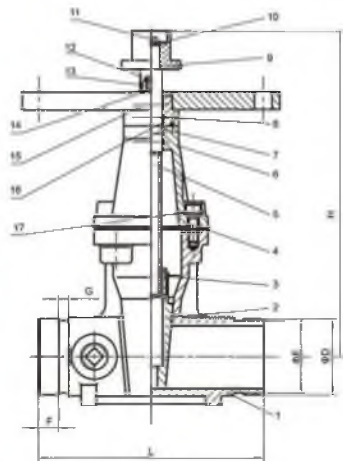

Vertical Type Indicator Post

Model: ZSQ

Technical Features

- Approvals: UL, CUL, FM
- Conforms to UL 789 & ULC / ORD-C789 & FM 1110
- Adjustable buried length: 570mm to 1500mm
- Used to identify the position of buried Gate Valves from 4" to 12"

Operation Manual

- Remove the indicator cover
- Adjust the length of the connecting rod according to buried depth and cut off the excessive part
- Connect the indicator post and gate valve which is in the closed position
- Adjust the indicator to the position of "SHUT"
- Tighten the bolts between the flange of the indicator post and post flange of gate valve
- Install the indicator cover

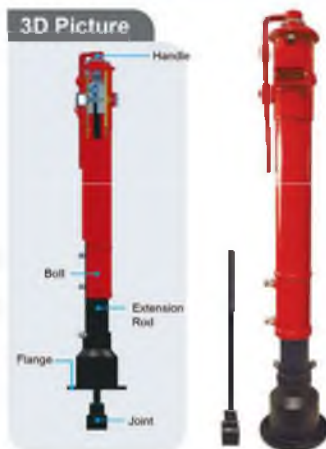

Material List

NO	Name	Material	Standard
1	Handle	Ductile Iron	ASTM A536
2	Driving Rod	Stainless Steel 304	ASTM A276
3	Indicator Cover	Cast Iron	ASTM A126
4	Housing	Cast Iron	ASTM A126
5	Keyhole Plate	A263 Gr.C	ASTM A36
6	Indicator Plate	A413.0	ASTM S12A
7	Screwed Plug	Steel 1035	ASTM A29
8	Extension Rod	A283 Gr.C	ASTM A36
9	Flange	Cast Iron	ASTM A126
10	Connecting Rod	Steel 1045	ASTM A29
11	Cotter Pin	Steel 1035	ASTM A29
12	Joint	Cast Iron	ASTM A126
13	Bolt	Steel 1035	ASTM A29
14	Bolt	Steel 1035	ASTM A29
15	Bolt	Steel 1035	ASTM A29
16	Drum Nut	Stainless Steel 304	ASTM A276
17	Keyhole Plate Gasket	EPDM	ASTM D2000
18	Indicator Flap	Organic Glass	
19	Bolt	Steel 1035	ASTM A29

Dimensions

Size	H(mm)(200PSI)		H(mm)(300PSI)	
	MIN.	MAX.	MIN.	MAX.
4"	850	1780	825	1756
5"	880	1810	890	1820
6"	917	1847	926	1856
8"	1022	1952	1012	1942
10"	1115	2045	1108	2038
12"	1204	2134	1188	2118

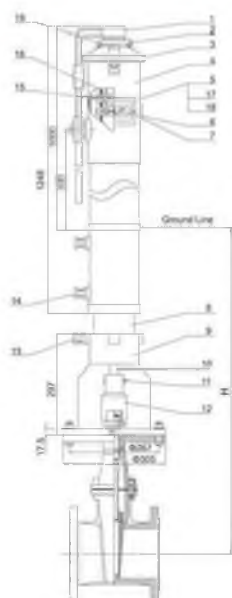

Technical Features

- Approvals: UL, CUL, FM
- Conforms to UL 789 & ULC / ORD-C789 & FM 1110
- Used to Operate a Valve Installed Behind the Wall

3D Picture

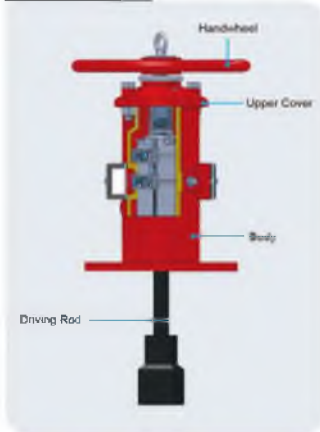

Operation Manual

- Adjust the length of the connecting rod according to the depth of gate valve and cut off the excessive part
- Install the indicator post to the wall
- Connect the indicator post and gate valve which is in the closed position
- Adjust the indicator to the position of "SHUT"

Material List

NO	Name	Material	Standard
1	Joint	Cast Iron	ASTM A536
2	Cotter Pin	Steel 1035	ASTM A29
3	Driving Rod	Steel 1045	ASTM A29
4	Main Body	Cast Iron	ASTM A126
5	Indicator Plate	A413 D	ASTM S12A
6	Nut, Gasket	Steel 1035	ASTM A29
7	Stud Bolt	Steel 1035	ASTM A29
8	Position Bracket	Stainless Steel 304	ASTM A276
9	Driver	Stainless Steel 304	ASTM A276
10	Retainer Ring For Stem	1566	ASTM A29
11	Upper Cover	Cast Iron	ASTM A126
12	Handwheel	Cast Iron	ASTM A126
13	Gasket	A283 Gr.C	ASTM A36
14	Lift Ring	Steel 1035	ASTM A29
15	Screw	Steel 1035	ASTM A29
16	Nut	Steel 1035	ASTM A29
17	Bolt	Steel 1035	ASTM A29
18	Screwed Plug	Steel 1035	ASTM A29
19	Bolt, Flat Gasket	Stainless Steel 304	ASTM A276
20	Keyhole Plate	A283 Gr.C	ASTM A36
21	Keyhole	Organic Glass	
22	Keyhole Plate Gasket	EPDM	ASTM D2000

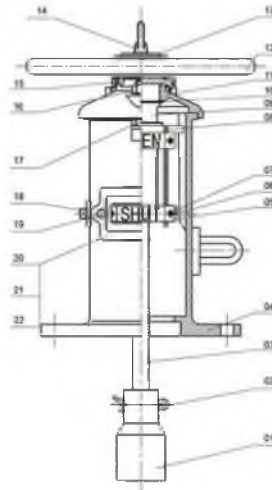

Flanged End

Technical Features

- Nominal Pressure: 300PSI
- Conforms: AWWA C508
- Flange Standard: ASME / ANSI B16.1 Class 125 or ASME / ANSI B16.42 Class 150 or BS EN1092-2 PN16 or GB / T9113.1
- Sizes: 2", 2½", 3", 4", 5", 6", 8", 10", 12"
- Face to Face Standard: ASME B16.10
- Approvals: UL, FM
- Maximum Working Pressure: 300PSI (Maximum Testing Pressure: 600PSI) conforms to UL 312 & FM class 1210
- Working Temperature: 80°C / 176°F
- Coating Details: Epoxy coated interior and exterior by Electrostatic Spray or coating upon request
- Applications:
Used both vertically and horizontally,
Used in one-way flow pipeline to prevent the water from back flow

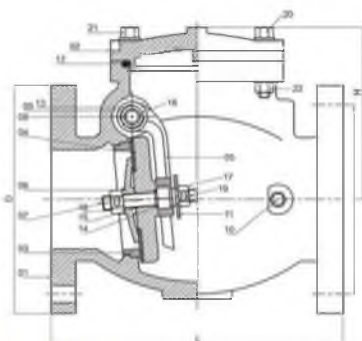

Valve Material List

NO	Name	Material	Standard
1	Body	Ductile Iron	ASTM A536 65-45-12
2	Bonnet	Ductile Iron	ASTM A536 65-45-12
3	Seat Ring	C95400	ASTM A148
4	Disc	Ductile Iron+EPDM	ASTM A536 65-45-12+ASTM D2000
5	Rocker Arm	Ductile Iron	ASTM A536 65-45-12
6	Baffle Plate	C95400	ASTM A148
7	Middle Stem	Stainless Steel 304	ASTM A276
8	Stem	Stainless Steel 304	ASTM A276
9	Bracket Screw	Stainless Steel 304	ASTM A276
10	Plug	C95400	ASTM A148
11	Gasket	Stainless Steel 304	ASTM A276
12	O-ring	EPDM	ASTM D2000
13	O-ring	EPDM	ASTM D2000
14	O-ring	EPDM	ASTM D2000
15	O-ring	EPDM	ASTM D2000
16	Bronze Bushing	Powder Metallurgy	
17	Nut	Stainless Steel 304	ASTM A276
18	Nut	Stainless Steel 304	ASTM A276
19	Coffler Pin	Stainless Steel 304	ASTM A276
20	Bolt	Steel 1045	ASTM A29
21	Bolt	Steel 1045	ASTM A29
22	Nut	Steel 1045	ASTM A29

Dimensions

Size	DN	L	D	H
2"	DN50	203	152	142
2½"	DN65	216	178	148
3"	DN80	241	191	163.5
4"	DN100	292	229	172
5"	DN125	330	254	237
6"	DN150	356	279	233
8"	DN200	485	343	301
10"	DN250	622	409	348
12"	DN300	696	483	419

Grooved End

Technical Features

- Nominal Pressure: 350PSI
- Groove standard: ANSI / AWWA C606 or Metric
- Sizes: 2", 2½", 3", 4", 5", 6", 8", 10", 12"
- Approvals: UL, FM
- Flange Standard: ASME / ANSI B16.1 Class 125 or ASME / ANSI B16.42 Class 150 or BS EN1092-2 PN16 or GB / T9113.1
- Maximum Working Pressure: 350PSI (Maximum Testing Pressure: 700 PSI) conforms to UL 312 & FM class 1210
- Maximum Working Temperature: 80°C / 176°F
- Coating Details: Epoxy coated interior and exterior by Electrostatic Spray or coating upon request
- Applications: Used in one-way flow pipeline to prevent the water from back flow
- Other Connections: Flange*Flange; Groove*Flange; Flange*Groove



Valve Material List

NO	Name	Material	Standard
1	Valve Body	Ductile Iron	ASTM A536 65-45-12
2	Bolt	Steel 1045	ASTM A29
3	Plug	Steel 1045	ASTM A29
4	Plug	Steel 1045	ASTM A29
5	Spring	Stainless Steel 304	ASTM A276
6	Hinge Pin	Stainless Steel 304/Ductile Iron	ASTM A276/ASTM A536 65-45-12
7	Clapper	Stainless Steel 304	ASTM A276
8	Seat	C95400	ASTM A148
9	Clamping Ring	Stainless Steel 304	ASTM A276
10	Locknut	Stainless Steel 304	ASTM A276
11	Facing Seal	EPDM	ASTM D2000
12	Gasket	EPDM	ASTM D2000
13	Bolt	Stainless Steel 304	ASTM A276
14	Plug	Steel 1045	ASTM A29

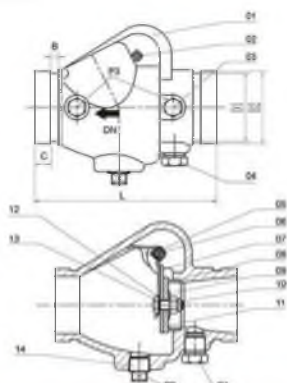

Dimensions

Size	L	D1	D2	B	C	P1	P2						P3		
2"	168	57.15	60.3	7.95	15.88	Rc½-14 ½-14NPT	Rc½-14 ½-14NPT	Rc¾-14 ¾-14NPT	Rc1-11 1-11.5NPT	Rc1 ½-11 1 ½-11.5NPT	Rc2-11 2-11.5NPT	Rc2 ½-10 2 ½-10NPT	Rc3-10 3-10NPT	Rc3 ½-19 3 ½-19NPT	Rc4-14 4-14NPT
2½"	181	69.09	73	7.95	15.88	Rc½-14 ½-14NPT	Rc¾-14 ¾-14NPT	Rc1-14 1-14NPT	Rc1-11 1-11.5NPT	Rc1 ½-11 1 ½-11.5NPT	Rc2-11 2-11.5NPT	Rc2 ½-10 2 ½-10NPT	Rc3-10 3-10NPT	Rc3 ½-19 3 ½-19NPT	Rc4-14 4-14NPT
3"	198	84.94	88.9	7.95	15.88	Rc½-14 ½-14NPT	Rc¾-14 ¾-14NPT	Rc1-14 1-14NPT	Rc1-11 1-11.5NPT	Rc1 ½-11 1 ½-11.5NPT	Rc2-11 2-11.5NPT	Rc2 ½-10 2 ½-10NPT	Rc3-10 3-10NPT	Rc3 ½-19 3 ½-19NPT	Rc4-14 4-14NPT
4"	234	110.08	114.3	9.53	15.88	Rc½-14 ½-14NPT	Rc¾-14 ¾-14NPT	Rc1-14 1-14NPT	Rc1-11 1-11.5NPT	Rc1 ½-11 1 ½-11.5NPT	Rc2-11 2-11.5NPT	Rc2 ½-10 2 ½-10NPT	Rc3-10 3-10NPT	Rc3 ½-19 3 ½-19NPT	Rc4-14 4-14NPT
5"	248	135.48	139.7	9.53	15.88	Rc½-14 ½-14NPT	Rc¾-14 ¾-14NPT	Rc1-14 1-14NPT	Rc1-11 1-11.5NPT	Rc1 ½-11 1 ½-11.5NPT	Rc2-11 2-11.5NPT	Rc2 ½-10 2 ½-10NPT	Rc3-10 3-10NPT	Rc3 ½-19 3 ½-19NPT	Rc4-14 4-14NPT
6"	270	160.78	165.1	9.53	15.88	Rc½-14 ½-14NPT	Rc¾-14 ¾-14NPT	Rc1-14 1-14NPT	Rc1-11 1-11.5NPT	Rc1 ½-11 1 ½-11.5NPT	Rc2-11 2-11.5NPT	Rc2 ½-10 2 ½-10NPT	Rc3-10 3-10NPT	Rc3 ½-19 3 ½-19NPT	Rc4-14 4-14NPT
8"	325	211.6	218.3	11.13	19.05	Rc½-14 ½-14NPT	Rc¾-14 ¾-14NPT	Rc1-14 1-14NPT	Rc1-11 1-11.5NPT	Rc1 ½-11 1 ½-11.5NPT	Rc2-11 2-11.5NPT	Rc2 ½-10 2 ½-10NPT	Rc3-10 3-10NPT	Rc3 ½-19 3 ½-19NPT	Rc4-14 4-14NPT
10"	457	266.3	273	12.7	19.05	Rc½-14 ½-14NPT	Rc¾-14 ¾-14NPT	Rc1-14 1-14NPT	Rc1-11 1-11.5NPT	Rc1 ½-11 1 ½-11.5NPT	Rc2-11 2-11.5NPT	Rc2 ½-10 2 ½-10NPT	Rc3-10 3-10NPT	Rc3 ½-19 3 ½-19NPT	Rc4-14 4-14NPT
12"	535	318.3	323.9	12.7	19.05	Rc½-14 ½-14NPT	Rc¾-14 ¾-14NPT	Rc1-14 1-14NPT	Rc1-11 1-11.5NPT	Rc1 ½-11 1 ½-11.5NPT	Rc2-11 2-11.5NPT	Rc2 ½-10 2 ½-10NPT	Rc3-10 3-10NPT	Rc3 ½-19 3 ½-19NPT	Rc4-14 4-14NPT

Technical Features

- Nominal Pressure: 250PSI
- Design Standard: AWWA C502
- Inlet flange size: 6" (DN150), Main Valve size: 133.4 mm / 5-1/4"
- One pumper nozzle: 4.5-4NH thread. Two hose nozzles, 2.5-7.5NH threads. Other kinds of threads are available
- Mechanical connector: AWWA / ANSI C153 / A21.536, Model No.: MH-1510A
- Flange connector: ASME B16.5 CLASS 150/DIN 2501 PN16, Model No.: MH-1510FA
- Painting Details: Red Polyurethane paint & Bitumen Black or painting upon request
- Note: Each hydrant is supplied with a hydrant wrench
- Approvals: UL 246 Listed, FM 1510 Approved

Installation

- Hydrants should be handled with care to avoid damage. It is recommended to keep hydrants closed until use
- If the hydrant is not to be used straight away then it is recommended to coat threads and other machined parts with anti-rust oil and the hydrant should be stored in a dry and ventilated area. For long-term storage, the hydrant should be checked regularly
- Before installation of hydrants, the connection should be free from dirt or other matter
- The positioning of the hydrant should be in accordance with local requirements. Ideally the pumper should face the street and all connections should be away from any obstruction to connecting hoses
- The inlet elbow should be placed on a solid surface and if possible brace the side opposite the incoming flow to reduce reaction stresses
- The underground parts of the hydrant should be surrounded with coarse gravel for support and drainage
- After the hydrant has been installed and tested, it is recommended to fully flush the hydrant before closing for service. Before replacing the nozzle caps, it is recommended to check for correct drainage of the hydrant on closing of the valve. This can be achieved by placing a hand over the nozzle opening, a suction should be felt

Operation

- Unscrew the nozzle caps and connect hoses
- Open the hydrant using the hydrant key (included) to the fully open position by turning the operation nut in an anti-clockwise direction. Do not force the hydrant to open further past the fully open position. Note that the hydrant valve is not intended to control the flow, it should be used in either the fully open or fully closed position
- To control flow, a pressure/flow control valve should be fitted to the nozzle outlets on the hydrant
- To close, turn the operation nut into a clockwise direction again, do not over tighten



3D Pictures

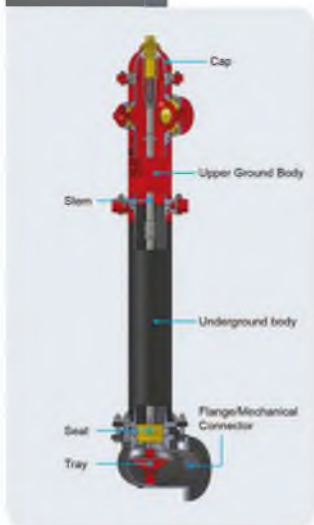

Maintenance

- Carry out a visual inspection for signs of significant corrosion which may impair performance
- Where possible, carry out leakage tests by opening one of the nozzle caps slightly and then open the hydrant valve. Once the air has escaped, tighten the hose cap and check for leaks
- Close hydrant and remove one nozzle cap so that the drainage can be checked
- Flush the hydrant
- Clean and lubricate all nozzle threads
- Clean the exterior of the hydrant and repaint if required

Buried Dimensions

L (mm)	3'6"	4'	4'6"	5'	5'6"	6'	6'6"	7'
	1063	1215	1368	1520	1673	1825	1978	2130

Material List

NO.	Name	Material	Standard
1	Flange Connector Or Mechanical Connector	Ductile Iron	ASTM A536 Grade 65-45-12
2	Locking Nut	Ductile Iron	ASTM A536 Grade 65-45-12
3	Connecting Rod	Steel 1045	ASTM A2929M
4	Locking Nut Gasket	EPDM	ASTM D2000,EPDM
5	Tray	Ductile Iron	ASTM A536 Grade 65-45-12
6	Sealed Rubber Sheet	EPDM	ASTM D2000,EPDM
7	Drain Hole Spring	316 Stainless Steel	ASTM A240
8	Connecting Cylinder	Ductile Iron	ASTM A536 Grade 65-45-12
9	Perforated Cylindrical Pin	Steel 1045	ASTM A2929M
10	Connecting Rod Sleeve	Steel 1045	ASTM A2929M
11	Clamp For Connection Tube	Ductile Iron	ASTM A536 Grade 65-45-12
12	Main Body On Ground	Ductile Iron	ASTM A536 Grade 65-45-12
13	65 Connector	C95400	ASTM B148
14	65 Cover Gasket	EPDM	ASTM D2000,EPDM
15	65 Cover	Ductile Iron	ASTM A536 Grade 65-45-12
16	Upper End Cover	Ductile Iron	ASTM A536 Grade 65-45-12
17	Thread Plug	C95400	ASTM B148
18	Screw Stem Nut	C95400	ASTM B148
19	Screw Nut Gasket	C95400	ASTM B148
20	Screw Nut Seat	C95400	ASTM B148
21	Bolt/nut	Steel 1035	ASTM A2929M
22	100 Cover	Ductile Iron	ASTM A536 Grade 65-45-12
23	Cylindrical Pin	Steel 1045	ASTM A2929M
24	Cover Chain	Gr B, ASTM A283-B	ASTM A283-B
25	Bolt/nut	Steel 1035	ASTM A2929M
26	Screw Stem	Steel 1045	ASTM A2929M
27	Cushion Rubber	EPDM	ASTM D2000,EPDM
28	Drain Hole Cover	C95400+EPDM	ASTM B148-ASTM D2000,EPDM
29	Seat	C95400	ASTM B148
30	Bolt/nut	316 Stainless Steel	ASTM A240
31	Seat Fixing Plate	Ductile Iron	ASTM A536 Grade 65-45-12
32	Bolt/nut	Steel 1035	ASTM A2929M
33	Annular Tubes	Steel 1045	ASTM A2929M
34	Platen	Ductile Iron	ASTM A536 Grade 65-45-12
35	Locking Nut Seat	Ductile Iron	ASTM A536 Grade 65-45-12
36	Check Turn Gasket	Gr B	ASTM A283-B
37	100 Connector	C95400	ASTM B148
38	100 Cover Gasket	EPDM	ASTM D2000,EPDM
39	Screw Stem Bushing	316 Stainless Steel	ASTM A240
40	Bolt	316 Stainless Steel	ASTM A240

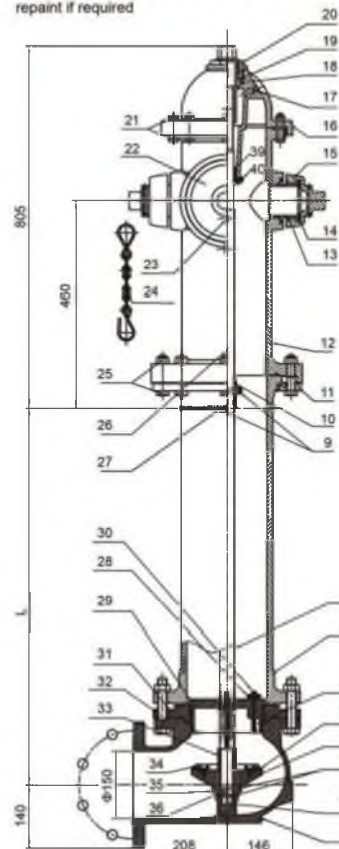

Архангельск (8182)63-90-72
 Астана (7172)727-132
 Астрахань (8512)99-46-04
 Барнаул (3852)73-04-60
 Белгород (4722)40-23-64
 Брянск (4832)59-03-52
 Владивосток (423)249-28-31
 Волгоград (844)278-03-48
 Вологда (8172)26-41-59
 Воронеж (473)204-51-73
 Екатеринбург (343)384-55-89
 Иваново (4932)77-34-06

Ижевск (3412)26-03-58
 Иркутск (395)279-98-46
 Казань (843)206-01-48
 Калининград (4012)72-03-81
 Калуга (4842)92-23-67
 Кемерово (3842)65-04-62
 Киров (8332)68-02-04
 Краснодар (861)203-40-90
 Красноярск (391)204-63-61
 Курск (4712)77-13-04
 Липецк (4742)52-20-81
 Киргизия (996)312-96-26-47

Магнитогорск (3519)55-03-13
 Москва (495)268-04-70
 Мурманск (8152)59-64-93
 Набережные Челны (8552)20-53-41
 Нижний Новгород (831)429-08-12
 Новокузнецк (3843)20-46-81
 Новосибирск (383)227-86-73
 Омск (3812)21-46-40
 Орел (4862)44-53-42
 Оренбург (3532)37-68-04
 Пенза (8412)22-31-16
 Казахстан (772)734-952-31

Пермь (342)205-81-47
 Ростов-на-Дону (863)308-18-15
 Рязань (4912)46-61-64
 Самара (846)206-03-16
 Санкт-Петербург (812)309-46-40
 Саратов (845)249-38-78
 Севастополь (8692)22-31-93
 Симферополь (3652)67-13-56
 Смоленск (4812)29-41-54
 Сочи (862)225-72-31
 Пенза (8412)22-31-16
 Таджикистан (992)427-82-92-69

Сургут (3462)77-98-35
 Тверь (4822)63-31-35
 Томск (3822)98-41-53
 Тула (4872)74-02-29
 Тюмень (3452)66-21-18
 Ульяновск (8422)24-23-59
 Уфа (347)229-48-12
 Хабаровск (4212)92-98-04
 Челябинск (351)202-03-61
 Череповец (8202)49-02-64
 Ярославль (4852)69-52-93